

ST60+ Depth Instrument

Owner's Handbook

Document reference: 81262-2
Date: December 2005

Preface

Important information

Safety notices



WARNING: Product installation & operation

This equipment must be installed and operated in accordance with the Raymarine instructions provided. Failure to do so could result in personal injury, damage to your boat and/or poor product performance.



WARNING: Electrical safety

Make sure you have switched off the power supply before you start installing this product.



WARNING: Navigational safety

Although we have designed this product to be accurate and reliable, many factors can affect its performance. Therefore, it should serve only as an aid to navigation and should never replace commonsense and navigational judgement. Always maintain a permanent watch so you can respond to situations as they develop.

EMC conformance

All Raymarine equipment and accessories are designed to the best industry standards for use in the recreational marine environment.

The design and manufacture of Raymarine equipment and accessories conform to the appropriate Electromagnetic Compatibility (EMC) standards, but correct installation is required to ensure that performance is not compromised.

Handbook information

To the best of our knowledge, the information in this handbook was correct when it went to press. However, Raymarine cannot accept liability for any inaccuracies or omissions it may contain.

In addition, our policy of continuous product improvement may change specifications without notice. Therefore, Raymarine cannot accept liability for any differences between the product and the handbook.

Product disposal



Waste Electrical and Electronic (WEEE) Directive

The WEEE Directive requires the recycling of waste electrical and electronic equipment.

Whilst the WEEE Directive does not apply to some of Raymarine's products, we support its policy and ask you to be aware of how to dispose of this product.

The crossed out wheellie bin symbol, illustrated above, and found on our products signifies that this product should not be disposed of in general waste or landfill.

Please contact your local dealer, national distributor or Raymarine Technical Services for information on product disposal.

Contents

Preface	i
Important information	i
Safety notices	i
WARNING: Product installation & operation	i
WARNING: Electrical safety	i
WARNING: Navigational safety	i
EMC conformance	i
Handbook information	i
Product disposal	ii
Contents	iii
Introduction	vii
Data inputs	vii
SeaTalk	vii
Stand alone operation	viii
Remote control	viii
Mounting options	viii
Depth transducers	viii
Parts supplied	ix
Chapter 1: Operation	1
1.1 Getting started	1
WARNING: Calibration requirement	1
Switching on and off.....	1
1.2 Normal operation	1
Depth information	1
Operating with fishfinder products	2
Current depth.....	2
Minimum & maximum depth	2
Alarms.....	3
Depth offsets	4
WARNING: Use the correct depth offset	4
1.3 Display settings	4
Illumination	4
Contrast.....	5
1.4 Pop-up Pilot	5
1.5 Remote control	5

Chapter 2: Maintenance & Troubleshooting 7

 2.1 Maintenance 7

 Servicing and safety 7

 Instrument 7

 Transducer..... 7

 Cabling..... 8

 2.2 Troubleshooting 8

 Preliminary procedures 8

 Fixing faults..... 8

 Technical support 9

 World wide web 9

 Telephone help line 9

 Help us to help you 9

Chapter 3: Installation 11

 3.1 Planning your installation 11

 Site requirements 11

 Transducer 11

 Instrument..... 13

CAUTION: Keep the rear of the instrument dry 13

 EMC installation guidelines..... 14

 Suppression ferrites..... 15

 Connections to other equipment..... 15

 3.2 Procedures 16

CAUTION: Maintain structural safety 16

 Unpacking..... 16

 Fitting the instrument..... 16

 Surface mounting 16

 Flush mounting 17

CAUTION: Use the correct screws..... 19

 Bracket mounting..... 20

 Fitting transducer 21

 Running transducer cable..... 21

 Connecting the instrument 22

 Types of connection 22

 Fitting ferrites..... 22

 Signal connections 22

 Power supply connections..... 23

CAUTION: Protect the power supply..... 23

 3.3 Switching on 25

WARNING: Calibration requirement 25

 EMC conformance..... 25

Chapter 4: Calibration	27
4.1 Introduction	27
4.2 User calibration	27
Depth units	27
Depth offset	28
Setting offset values	29
WARNING: Use the correct depth offset	29
Shallow alarm lock	30
Pop-up pilot	30
Leaving User calibration	30
4.3 Intermediate calibration	30
Leaving Intermediate calibration	31
4.4 Dealer calibration	31
User calibration on/off	31
Response settings	32
Boat show mode	33
CAUTION: Do NOT enable Boat Show Mode	33
Factory defaults	33
Leaving Dealer calibration	33
Glossary	35
Index	37

Introduction

Thank you for purchasing a Raymarine product. We are sure your ST60+ instrument will give you many years of trouble-free operation.

This handbook describes how to install and use the Raymarine ST60+ Depth instrument. This instrument provides accurate depth information, in either feet, meters or fathoms, on a high quality Liquid Crystal Display (LCD). The instrument is constructed in a rugged weather-proofed case to provide reliable performance, even under the most demanding conditions.

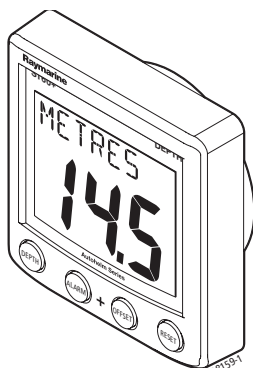

Data inputs

The ST60+ Depth instrument receives data either from an appropriate depth transducer and/or from a SeaTalk instrumentation system.

SeaTalk

SeaTalk enables a number of compatible instruments to operate as a single, integrated navigational system. Instruments in a SeaTalk system are linked by means of a single cable, which feeds both power and data. Instruments can therefore be added to the system by plugging them into the network. SeaTalk is flexible enough to adapt to any number of compatible instruments without requiring a central processor. SeaTalk can also communicate via an interface, with non-SeaTalk equipment using the internationally-accepted National Marine Electronics Association (NMEA) protocol.

In a SeaTalk system, each instrument can be either a master or dedicated repeater unit. A master instrument is directly connected to a transducer (the device that provides the raw data), and provides data and control appropriate to its function, to all other equipment on the SeaTalk network. A repeater instrument is not

directly connected to a transducer but displays information provided by other equipment in the SeaTalk network.

The ST60+ Depth instrument can fulfil both master and repeater roles.

Stand alone operation

In Stand alone operation, the ST60+ Depth instrument is connected only to the relevant transducer and does not display information from, or provide information to, any other instruments.

Remote control

When connected to SeaTalk, the ST60+ Depth instrument can be controlled remotely by a SeaTalk Remote Keypad Unit, to provide instant remote access to the various display readouts.

Mounting options

A standard ST60+ instrument is surface-mounted at the required location. If you do not want to surface mount your ST60+ instrument, options are available for:

- Flush mounting. If you have ordered the flush mounting option a flush-mount bezel and four fixing screws are provided.
- Bracket mounting.

Depth transducers

Various optional transducer types are available to suit different situations and hull types. Refer to *Chapter 3, Installation*, for details.

Parts supplied

Unpack your ST60+ instrument and check that the following items are present:

- Item 1, ST60+ Depth instrument with standard bezel for surface mounting.
- Item 2, Fixing studs (2).
- Item 3, Thumb nuts (2).
- Item 4, Gasket.
- Item 5, Depth transducer.
- Item 6, SeaTalk interconnection cable.
- Item 7, Power cable.
- Item 8, Instrument Cover.
- Item 9, Owner's Handbook. A Warranty document and fitting templates are included in this Handbook.
- Item 10, Cue Card.

Spare spade terminals are also provided, to re-terminate the transducer cable if it has to be cut to facilitate installation.

Note: *The above packing list is for an ST60+ Depth system. Where an instrument is purchased separately, a transducer is not included.*

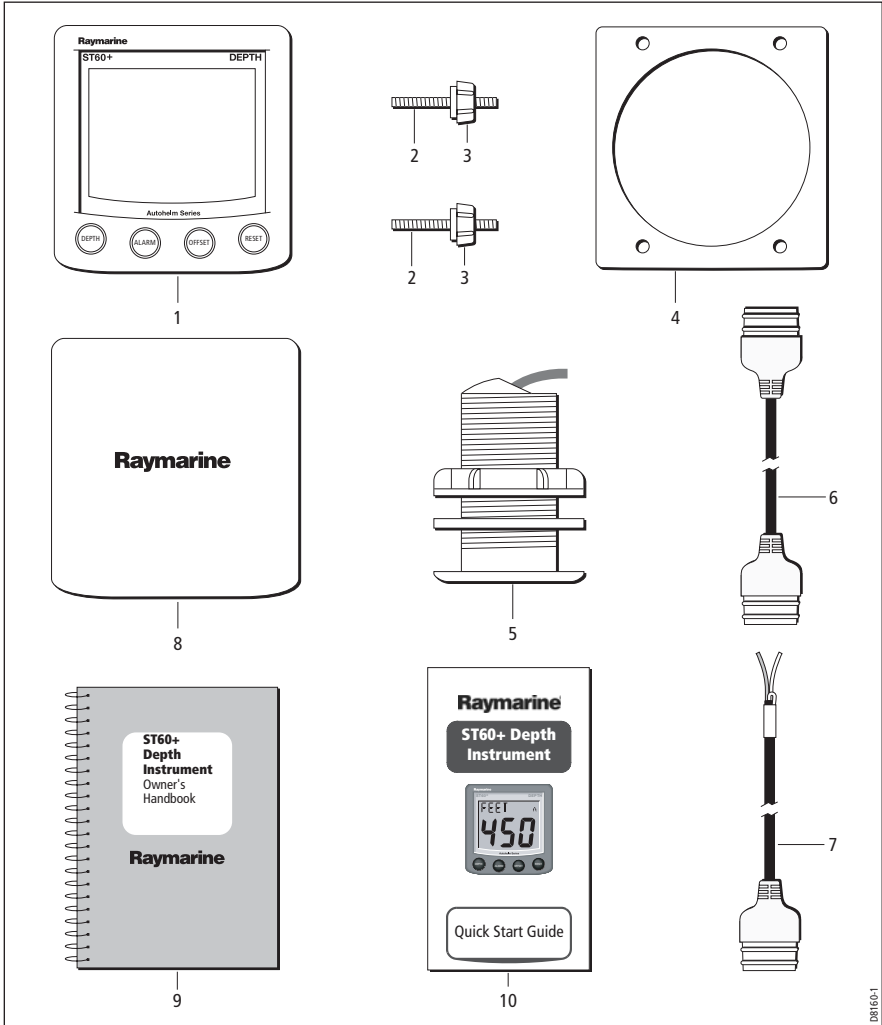

Chapter 1: Operation

1.1 Getting started

This handbook describes how to operate, maintain and install the Raymarine ST60+ Depth instrument. Your ST60+ Depth instrument provides depth information, plus maximum and minimum depth alarms.



WARNING: Calibration requirement

To ensure that this product performs at its best on your boat, you MUST calibrate it before use, in accordance with the instructions in *Chapter 4, Calibration*. Do NOT use the product until you have successfully calibrated it.

Switching on and off

All the time that power is applied to the instrument, you can use the **depth** button to switch the instrument off and on as follows:

- To switch the instrument off, hold down the **depth** button for approximately 5 seconds. After this time, a switch off count down of 4 seconds occurs. Keep the **depth** button pressed during this period, to switch off the instrument.
- To switch the instrument back on, hold down the **depth** button for approximately 1 second.

When the power supply is switched off, none of the instrument buttons (including **depth**) has any effect.

Notes: (1) *Each time power to the instrument is switched on, the instrument is initially in the on condition. You do not need to use the **depth** button to switch the instrument on.*

(2) *When the instrument is on, the operation of the **depth** button will perform other operating functions, as described below.*

1.2 Normal operation

Use the flow charts in this Chapter to operate your ST60+ Depth instrument. The flow charts show the sequence of button presses and displays for the various operating tasks. All button presses are momentary unless otherwise stated.

Depth information

When power is switched on, the **depth** button gives you access to the current depth, minimum depth and maximum depth readings. Refer to the *Depth information* flow diagram (below) to access the information you want.

You can reset the MIN and MAX values by pressing the **reset** button for 3 seconds.

Operating with fishfinder products

Depth information is normally obtained from the Depth transducer, fitted as part of the ST60+ Depth system. However, when the ST60+ Depth instrument is connected to a SeaTalk system to which a compatible fishfinder is also connected, the depth information is provided by the fishfinder all the time the fishfinder is switched on.

Current depth

The current depth is shown in either FEET, FATHOMS or METRES. You can select the units you want during User calibration.

The current depth screen also displays depth-trend indicator arrows to show whether the depth is increasing or decreasing. A rising sea-bed is indicated by \wedge and a lowering sea-bed by \vee .

If there is no depth signal from the transducer for more than 30 seconds, the last known depth is displayed and LAST flashes at the top of the screen. If depth information is not received from the transducer or from SeaTalk, then dashes are displayed.

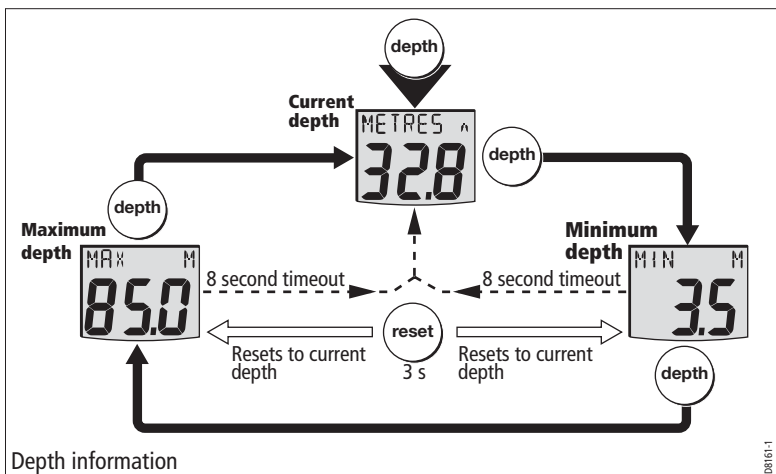

Minimum & maximum depth

The minimum and maximum depth values are reset at power up. You can also reset each one manually to the current depth, by holding in the reset button for 3 seconds.

The screens show the maximum/minimum depth since the last reset, but time out to the current depth screen if no user action occurs for 8 seconds.

Alarms

An alarm condition occurs if:

- The depth is less than the SHALLOW or SHALLOW anchor level.
- The depth is more than the DEEP anchor level.
- The DEEP level value is crossed (when the seabed rising or falling).

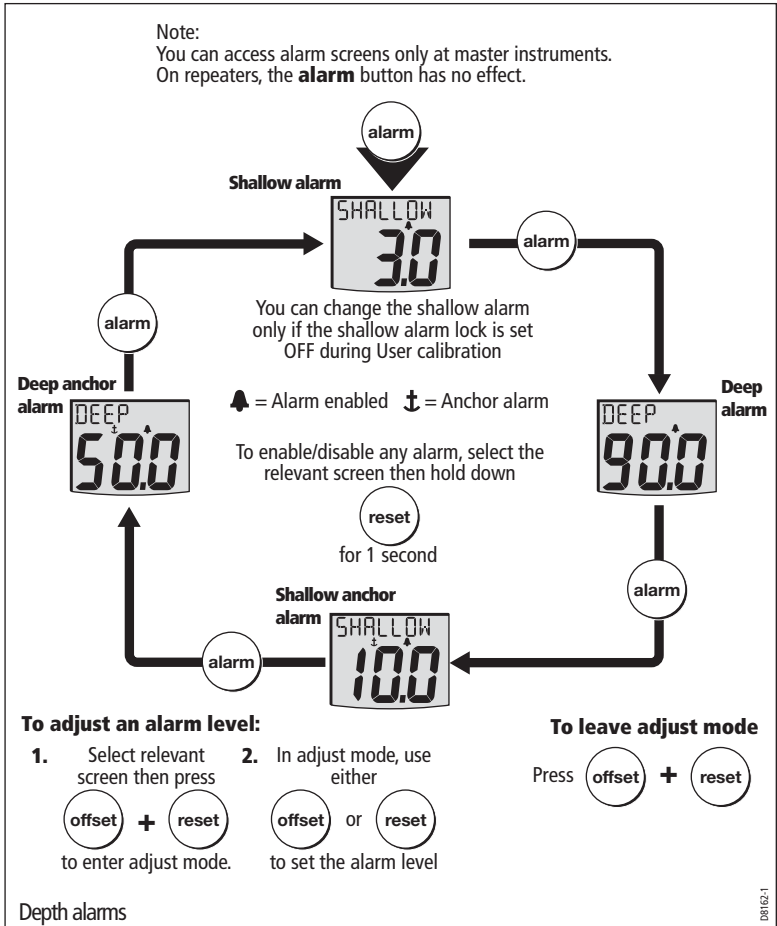

An alarm condition is indicated by an audible beep and a flashing alarm symbol (♣) on the display. The display will also show the relevant caption, either SHALLOW or DEEP, and for anchor alarms an anchor symbol (⚓).

When the instrument is operating as a master, you can check the alarm levels and if necessary set them up (see *Depth alarms* flow chart). To do this, use the alarm button to select the required alarm level, then:

- To enable or disable the alarm, hold in the **reset** button for 1 second. If an alarm is disabled, the associated screen shows an OFF legend.
- To change the value of the alarm level, press the **offset** and **reset** buttons together to enter adjust mode, then use these buttons individually to set the required value.

Depth offsets



WARNING: Use the correct depth offset

The use of the correct depth offset is critical to the safety of the vessel. If incorrect offset values are applied, this could result in misleading depth information being displayed with a consequent risk of running aground. Take great care to ensure you set the correct value, as described in *Chapter 4, Calibration*.

Depths are measured from the transducer to the sea bed. However, offsets to the actual distances measured can be applied during calibration (see *Chapter 4, Calibration*), so that the displayed depth reading represents either the depth from the keel or the depth from the waterline (W/L).

To see the offsets applied on your vessel, press the **offset** button. If the instrument is operating as a master, the display will show the size of the offset (either positive or negative) and the appropriate legend:

- When the offset is a positive value, the legend W/L is displayed.
- When the offset is a negative value, the legend KEEL is displayed.
- When the offset is zero, the legend OFFSET is displayed. With zero offset applied, the displayed depth reading is measured from the transducer.

1.3 Display settings

Illumination

When the instrument is first powered up, the display illumination is set to its lowest (courtesy) level, to facilitate initial access to the buttons. To adjust the level of illumination:

1. Hold down the **depth** button for approximately one second, to enter the illumination-adjust mode.
2. There are four preset illumination levels. Momentarily press the **depth** button to cycle through these levels until you reach the level you want.

3. Press any other button to leave the illumination-adjust mode.

Note: *The display will time out to normal operation 7 seconds after the last button press.*

Contrast

To adjust the display contrast:

1. Enter the illumination-adjust mode as described above.
2. Hold down the **depth** button for a further two seconds approximately, to enter the contrast-adjust mode.
3. There are four preset contrast settings. Momentarily press the **depth** button to cycle through these settings until you achieve optimum display quality.
4. Press any other button to leave the contrast-adjust mode.

Note: *The display will time out to normal operation 7 seconds after the last button press.*

1.4 Pop-up Pilot

A Pop-up Pilot facility enables instruments connected to SeaTalk to constantly monitor any changes to the autopilot mode and to the course settings. If one of these parameters changes, the new value is immediately displayed on the ST60+ instrument for 5 seconds, after which time the display reverts to the previous display.

This facility can be enabled or disabled during User calibration (see *Chapter 4, Calibration*).

1.5 Remote control

When it is connected to SeaTalk, the ST60+ Depth instrument can be controlled remotely with a SeaTalk Remote Keypad Unit. Remote control of an instrument is indicated by a REMOTE legend on the display, to indicate that the keypad has control.

Details on how to use the remote control facility can be found in the *SeaTalk Remote Keypad Owner's Handbook*.

Chapter 2: Maintenance & Troubleshooting

2.1 Maintenance

Servicing and safety

- Raymarine equipment should be serviced only by authorised Raymarine service technicians. They will ensure that servicing procedures and replacement parts used will not affect performance. There are no user-serviceable parts in any Raymarine product.
- Some products generate high voltages, and so never handle the cables/connectors when power is being applied to the equipment.
- When powered up, all electrical equipment produces electromagnetic fields. These can cause adjacent pieces of electrical equipment to interact with one another, with a consequent adverse effect on operation. In order to minimise these effects and enable you to get the best possible performance from your Raymarine equipment, guidelines are given in the installation instructions, to enable you to ensure minimum interaction between different items of equipment, i.e. ensure optimum Electromagnetic Compatibility (EMC).
- Always report any EMC-related problem to your nearest Raymarine dealer. We use such information to improve our quality standards.
- In some installations, it may not be possible to prevent the equipment from being affected by external influences. In general this will not damage the equipment but it can lead to spurious resetting action, or momentarily may result in faulty operation.

Instrument

Certain atmospheric conditions may cause condensation to form on the instrument window. This will not harm the instrument and can be cleared by increasing the illumination setting to Level 3.

Periodically clean your ST60+ instrument with a soft damp cloth. Do NOT use chemical and abrasive materials to clean the instrument.

Transducer

Refer to the Installation and Maintenance instructions supplied with the transducer.

Cabling

Examine all cables for chafing or other damage to the outer shield, and where necessary, replace and re-secure.

2.2 Troubleshooting

Preliminary procedures

Changes in the electronic environment may adversely affect the operation of your ST60+ equipment. Typical examples of such changes are:

- Electrical equipment has recently been installed or moved aboard your vessel.
- You are in the vicinity of another vessel or shore station emitting radio signals.

If you appear to have a problem, first ensure that the EMC requirements are still being met before further investigating the problem.

Fixing faults

All Raymarine products are subjected to comprehensive test and quality assurance programmes prior to packing and shipping. However, if a fault occurs, the following table may help to identify and rectify the problem.

Fault	Cause	Remedy
Display blank	No power supply	Check power supply & ensure instrument is switched on. Check SeaTalk cabling and connector security Check fuse/circuit breaker
No transfer of information between SeaTalk instruments (e.g. illumination levels).	SeaTalk cable or connector fault	Check security of SeaTalk connectors. Check condition of SeaTalk cables. Isolate faulty instrument by disconnecting instruments one by one.
Failure of a group of SeaTalk instruments.	SeaTalk cable or connector fault	Check the security of SeaTalk connectors between functioning and non-functioning instruments
LAST flashing or dashes displayed continuously (depth greater than 3 ft)	Transducer cable or connector fault	Check the condition of the transducer cable and the security of the connections
LAST flashes when under way	Aerated water due to -boat wakes, propeller wash etc.	Ensure reading stabilizes when clear of disturbed water.

Technical support

Raymarine provides a comprehensive customer support service, on the world wide web and by telephone help line. Please use either of these facilities if you are unable to rectify a problem.

World wide web

Please visit the Customer Support area of our web site at:

www.raymarine.com

As well as providing a comprehensive Frequently Asked Questions section and servicing information, the web site gives e-mail access to the Raymarine Technical Support Department and a details of the locations of Raymarine agents, worldwide.

Telephone help line

If you do not have access to the world wide web, please call our help line.

In the USA, call:

- +1 800 539 5539, extension 2444 or
- +1 603 881 5200 extension 2444

In the UK, Europe the Middle East or the Far East, call:

- +44 (0) 23 9271 4713 (voice)
- +44 (0) 23 9266 1228 (fax)

Help us to help you

When requesting service, please quote the following product information:

- Equipment type.
- Model number.
- Serial number.
- Software issue number.

To find out the software version number of your ST60+ Depth instrument:

1. During normal operation, hold down the **depth** and **alarm** buttons for approximately 4 seconds, to display the VERSION screen.

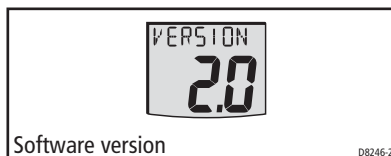

2. Note the software version number, then hold down the **depth** and **alarm** buttons for approximately 2 seconds, to return to normal operation.

Chapter 3: Installation

This chapter describes how to install the ST60+ Depth instrument, and associated depth transducer. The transducer is fitted in the hull of the vessel and is connected by cable to the rear of the instrument. The actual type of transducer depends on the type of hull in which it is to be installed.

For advice, or further information regarding the installation of this equipment, please contact the Raymarine Product Support Department or your own National Distributor.

3.1 Planning your installation

Before starting the installation, spend some time considering the best positions for both transducer and instrument, such that the *Site Requirements* and the *EMC installation guidelines* (below) are satisfied.

Site requirements

Transducer

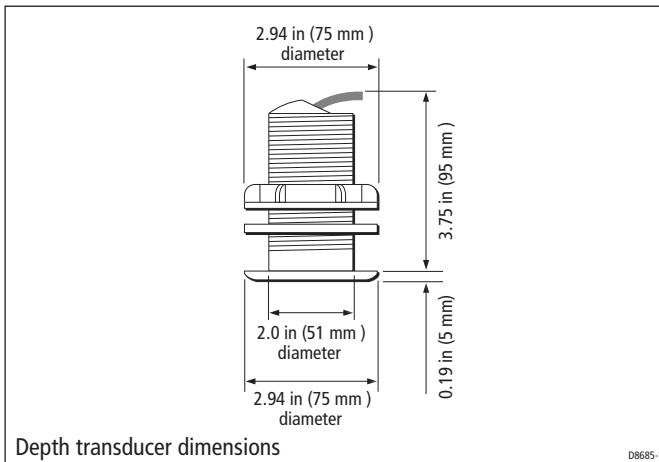

The transducer types required for the various hull types are as follows:

Hull material	Transducer type
Glass reinforced plastic (GRP)	31-188-4-02 Through hull plastic M78718 Retractable through hull
Steel	31-188-4-02 Through hull plastic M78718 Retractable through hull
Aluminium	31-188-4-02 Through hull plastic M78718 Retractable through hull
Wood	31-188-4-02 Through hull bronze M78719 Retractable through hull

Other transducer types are also available for specific requirements. For further details, contact your local Raymarine dealer.

For accurate depth readings the transducer should be sited within the clear water flow areas indicated by the shaded areas in the following diagram.

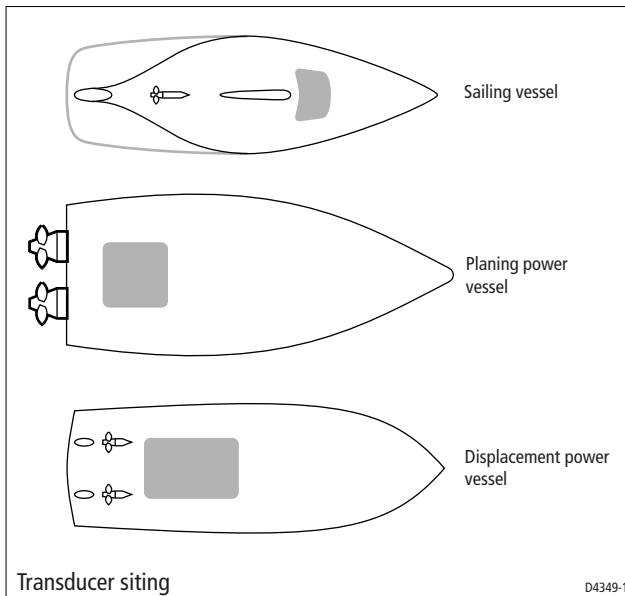

The transducer should also:

- Be ahead of the propellers (by a minimum of 10% of the water line length).
- Be at least 6 in (150 mm) away from the keel (ideally ahead of the keel if a sailing yacht).

- Be as near as possible to the center line of the vessel.
- Be clear of other through-hull fittings or projections.
- Have sufficient clearance inside the hull to fit the nut.
- Have 4 in (100 mm) of headroom to allow for withdrawal.
- Be within 10° of the vertical, forward, aft and athwart ships.

There must also be a viable route for the transducer cable to be routed to the instrument.

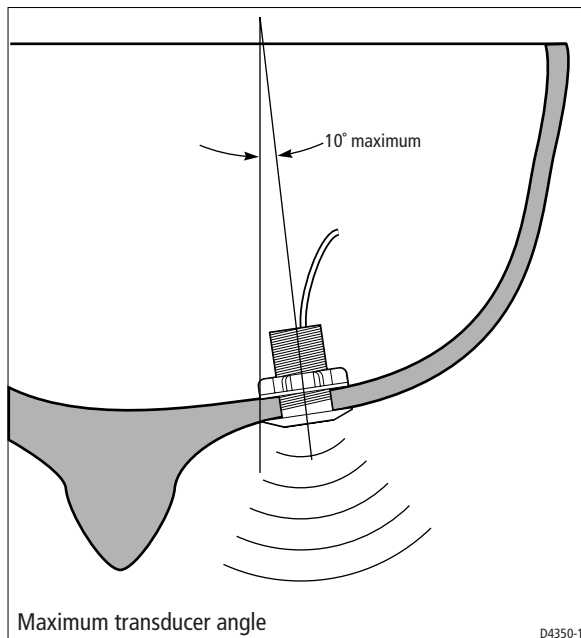

Instrument

CAUTION: Keep the rear of the instrument dry

Keep the rear of instrument dry. Failure to observe this caution could result in damage if water enters the instrument through the breathing hole or comes into contact with the electrical connectors.

ST60+ instruments can be fitted either above or below deck, provided the rear of the instrument is sited where it is protected from contact with water.

Each instrument must also be positioned where:

- It is easily read by the helmsman.

- It is protected against physical damage.
- It is at least 9 in (230 mm) from a compass.
- It is at least 20 in (500 mm) from radio receiving equipment.
- There is reasonable rear access for installation and servicing.

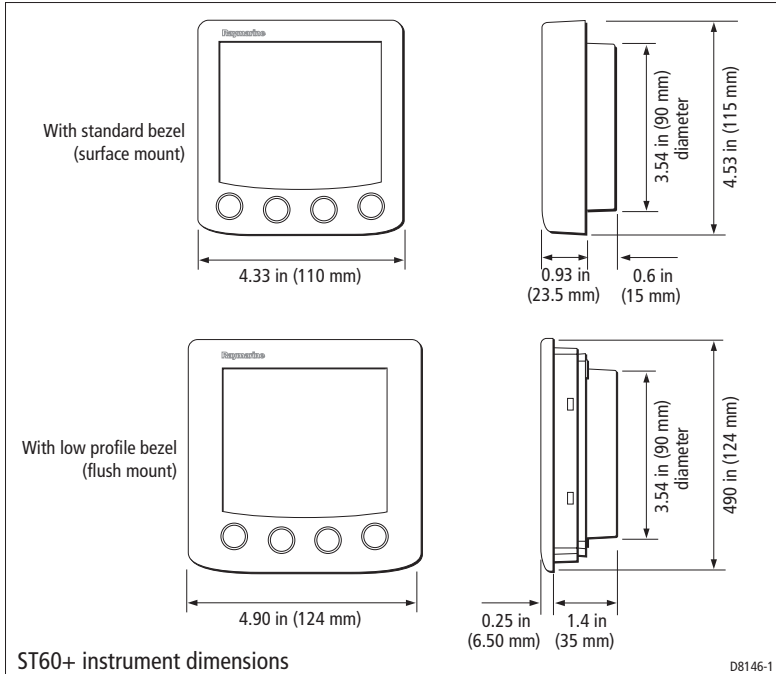

EMC installation guidelines

All Raymarine equipment and accessories are designed to the best industry standards for use in the recreational marine environment.

Their design and manufacture conforms to the appropriate Electromagnetic Compatibility (EMC) standards, but correct installation is required to ensure that performance is not compromised. Although every effort has been taken to ensure that they will perform under all conditions, it is important to understand what factors could affect the operation of the product.

The guidelines given here describe the conditions for optimum EMC performance, but it is recognized that it may not be possible to meet all of these conditions in all situations. To ensure the best possible conditions for EMC performance within the constraints imposed by any location, always ensure the maximum separation possible between different items of electrical equipment.

For **optimum** EMC performance, it is recommended that **wherever possible**:

- Raymarine equipment and cables connected to it are:
 - At least 3 ft (1 m) from any equipment transmitting or cables carrying radio signals e.g. VHF radios, cables and antennas. In the case of SSB radios, the distance should be increased to 7 ft (2 m).
 - More than 7 ft (2 m) from the path of a radar beam. A radar beam can normally be assumed to spread 20 degrees above and below the radiating element.
- The equipment is supplied from a separate battery from that used for engine start. Voltage drops below 10 V in the power supply to our products, and starter motor transients, can cause the equipment to reset. This will not damage the equipment, but may cause the loss of some information and may change the operating mode.
- Raymarine specified cables are used. Cutting and rejoining these cables can compromise EMC performance and must be avoided unless doing so is detailed in the installation manual.
- If a suppression ferrite is attached to a cable, this ferrite should not be removed. If the ferrite needs to be removed during installation it must be reassembled in the same position.

Suppression ferrites

The following illustration shows typical cable suppression ferrites used with Raymarine equipment. Always use the ferrites supplied by Raymarine.

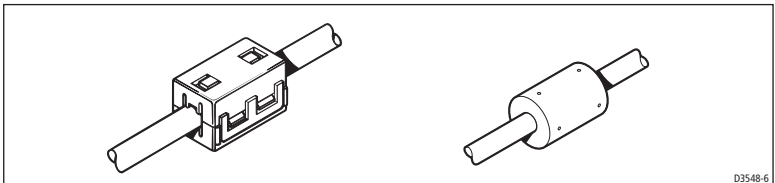

Connections to other equipment

If your Raymarine equipment is to be connected to other equipment using a cable not supplied by Raymarine, a suppression ferrite **MUST** always be attached to the cable near the Raymarine unit.

3.2 Procedures

As it is not practical to describe procedures for all possible installation scenarios, the procedures given here describe the broad requirements for installing depth transducers and the ST60+ Depth instrument. Adapt these procedures as appropriate, to suit your individual requirement.

CAUTION: Maintain structural safety

Where it is necessary to cut holes (e.g. for cable routing and instrument mounting), ensure that these will not cause a hazard by weakening critical parts of the vessel's structure.

Unpacking

Unpack your ST60+ equipment and check that the items described in the *Preface* are present.

Each ST60+ instrument is supplied with a standard bezel for surface mounting. Optional mounting kits are available for flush mounting and bracket mounting the instrument. If you have ordered the flush mounting option a flush mount bezel and four fixing screws are also provided.

Fitting the instrument

The ST60+ Depth instrument can be installed using one of a number of different mounting options:

- Surface mounting. Gives a profile of approximately 0.95 in (24 mm).
- Flush mounting. Gives a profile of approximately 0.25 in (6 mm).
- Bracket mounting.

The ST60+ instruments can also be mounted behind a panel with just the instrument dial and buttons visible.

Surface mounting

To surface mount your ST60+ instrument (see the *Surface mounting* illustration):

1. Ensure that:
 - The selected location is clean, smooth and flat.
 - There is sufficient space behind the selected location to accommodate the rear of the instrument and connectors.
2. Apply the surface mount template (supplied at the rear of this handbook) to the selected location and mark the centers for the fixing studs (1) and the aperture (3) that will take the rear casing of the instrument.
3. Drill out the two 0.2 in (5 mm) fixing stud clearance holes (2).

4. Cut out the clearance hole (3) then remove the template.
5. Peel off the protective sheet from the self-adhesive gasket (4) then stick the gasket into position on the rear of the instrument.

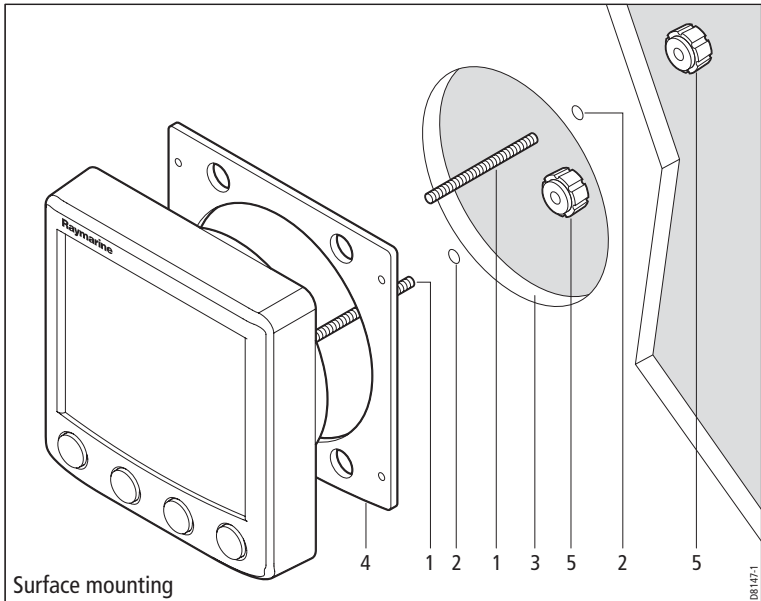

6. Screw the two fixing studs into the threaded sockets on the rear of the instrument.
7. Mount the assembled instrument, studs, bezel and gasket into the panel. Secure from behind with the thumb nuts (5).

Flush mounting

The Flush Mounting Kit uses a flush mount bezel to reduce the fitted profile of the instrument, to approximately 0.25 in (6 mm) above the panel fascia.

Fitting the flush mount bezel

In order to flush-mount your ST60+ instrument, you must first replace the standard bezel with the flush mount bezel as follows:

1. Hold the instrument in both hands with the display towards you.
2. Using both thumbs, gently press an upper corner of the instrument from the bezel, then remove the bezel from the instrument. Retain the rubber keypad which is released when the bezel is removed.

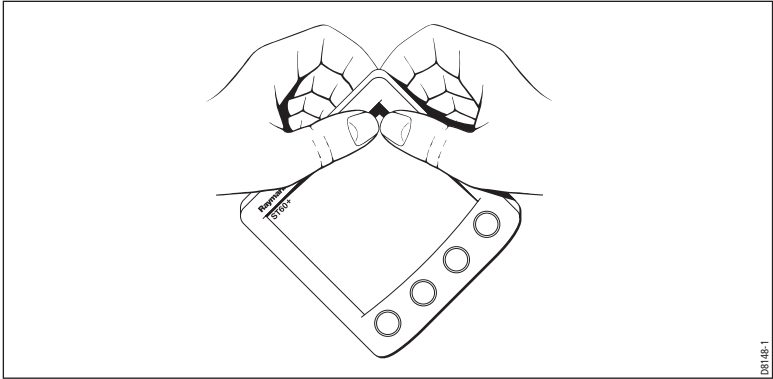

D8148-1

3. Referring to the *Fitting the flush mount bezel* illustration, insert the panel seal (8) in the corresponding recess on the back of the flush mount bezel (7).
4. Place the instrument (11) face upwards on a flat surface, then place the rubber keypad (10) in position around the display window (i.e. so that each button outline is located over its associated button on the instrument).

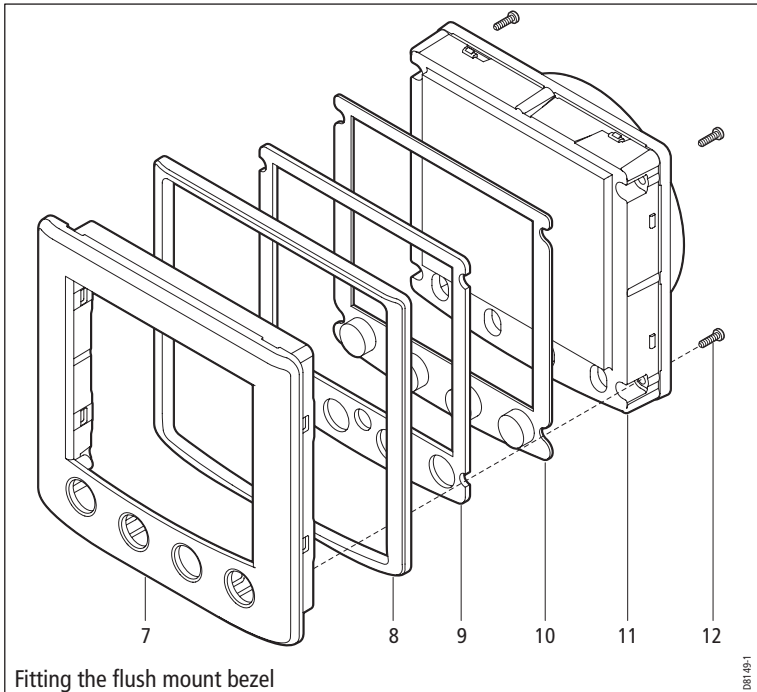

Fitting the flush mount bezel

D8149-1

5. Place the keypad seal (9) in position on the keypad (i.e. so that the holes in the seal accept the appropriate keypad buttons).
6. Place the assembled flush mount bezel and panel seal, in position on the instrument, so that the rubber keys are correctly located in the holes on the bezel, then clip the bezel and instrument together.

CAUTION: Use the correct screws

It is essential that only screws of the correct size are used to secure the instrument to the bezel. Failure to observe this caution could result in damage to both the instrument and the bezel.

7. Using the four, self-tapping screws (12) provided, secure the instrument and bezel together. Fit the screws from the rear of the instrument and tighten them sufficiently to secure the instrument and bezel together. **DO NOT OVERTIGHTEN.**

Flush mounting procedure

Flush mount your instrument (see the *Flush mounting* illustration) as follows:

1. Assemble the ST60+ instrument and flush mount bezel as described under *Fitting the flush mount bezel*.

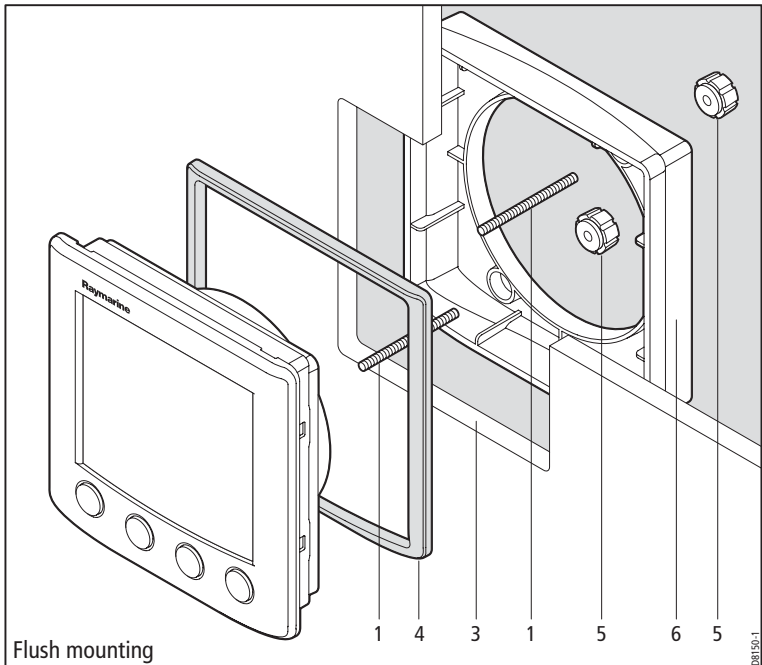

2. Ensure that:
 - The panel on which you intend to mount the instrument is between 0.12 in (3 mm) and 0.78 in (20 mm) thickness.
 - The selected location is clean, smooth and flat.
 - There is sufficient space behind the selected location to accommodate the rear of the instrument and connectors.
3. Apply the flush mount template (supplied at the rear of this handbook) to the selected location and mark out the aperture into which the assembled instrument and bezel will sit.
4. Cut out the aperture (3) for the assembled instrument and bezel and remove the template.
5. Peel off the protective sheet from the self-adhesive gasket (4) then stick the gasket into position on the rear of the bezel.
6. Screw the two fixing studs (1) into the threaded sockets on the rear of the instrument.
7. Mount the assembled instrument, studs, bezel and gasket into the panel.
8. Locate the flush mount bracket (6) onto the fixing studs and secure the assembly to the panel with the thumb-nuts (5).

Bracket mounting

A Control Unit Mounting Bracket (Part No. E25009) enables you to mount your ST60+ instrument in locations where other forms of mounting are impractical. Although this provides a useful alternative method for securing your instrument, it is only suitable for use in positions where the instrument will not be exposed to water.

To bracket mount your ST60+ instrument, do so in accordance with the Control Unit Mounting Bracket Instruction Sheet.

Fitting transducer

The ST60+ Depth instrument is supplied, with a through-hull depth transducer.

The depth transducer is supplied with detailed instructions for installation and maintenance. Before attempting to install the depth transducer, read these instructions and the *Site requirements* for transducers described in this Chapter.

Once you are satisfied you can meet all the installation requirements, install the transducer in accordance with the accompanying installation instructions.

Running transducer cable

Each transducer type has a 14 m (45 ft) cable fitted with spade terminals for connection to the ST60+ Depth instrument. The manner in which you run the cable will depend on the locations of the transducer and instrument.

Observing the following guidelines, run the transducer cable to the ST60+ Depth instrument:

- If the cable has to be fed through the deck, always use a proprietary deck gland.
- Where cables are fed through holes, always use grommets to prevent chafing.
- Secure long cable runs so they do not present a hazard.
- Do not route the cable through bilges.
- Wherever possible, route the cable away from fluorescent lights, engines, radio transmitting equipment, as these may cause interference.
- Although the transducer cable is fitted with spade connectors for direct connection to the rear of the instrument, it may be necessary to remove these to facilitate installation, e.g. if the cable has to be routed through narrow apertures. Extra spade connectors are provided, to replace any that are removed when running the cable. When fitting spade connectors, prepare the cable as at (a) in the following illustration, then fold back the wire strands and insert into the spade connector as at (b). Ensure the wire strands do not extend beyond the rear of the spade connector insulation, then crimp the connector to the wire.

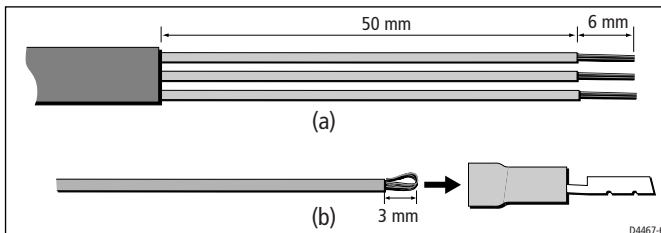

Connecting the instrument

Types of connection

The ST60+ Depth instrument, can be connected:

- As a stand-alone, master instrument connected directly to the Depth transducer.
- As a SeaTalk repeater.
- To fulfil both repeater and master roles by being connected both to the transducer and to SeaTalk.

If instruments are connected to SeaTalk, no separate power connection is necessary. Where a SeaTalk system includes an autopilot, the power for the system is provided by the autopilot.

A range of Raymarine SeaTalk extension cables is available to connect separated instruments. These cables are supplied with a SeaTalk connector fitted to each end. A junction box can be used to join cables.

Fitting ferrites

If you are going to connect a Depth transducer to an ST60+ Depth instrument, fit suppression ferrites near the instrument end of the SeaTalk and transducer cables, as follows.

1. Release the catch on the ferrite, open it up then snap it closed around the cable.
2. Position the ferrite as close as possible to the instrument end of the cable (maximum 1 foot (300 mm) from the end) and fit a tie-wrap on the cable either side of the ferrite, to hold it in position.

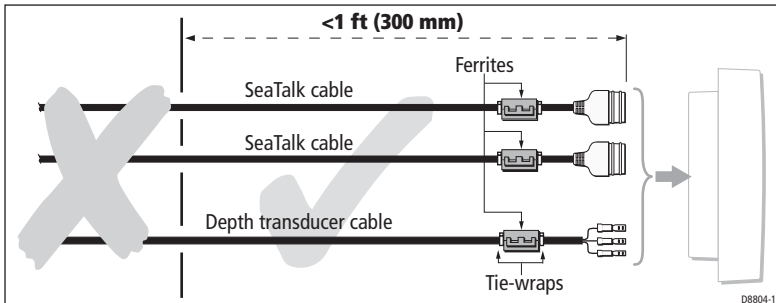

Signal connections

Make the necessary connections to your ST60+ instrument (see the *Connections to ST60+ Depth instrument* illustration).

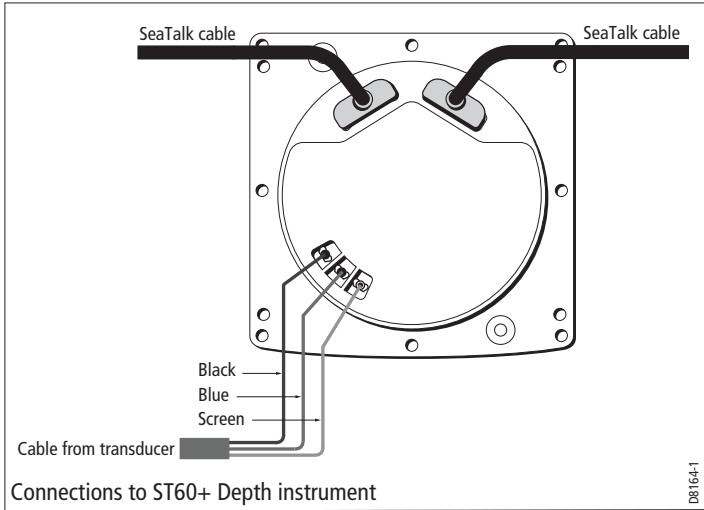

Power supply connections

CAUTION: Protect the power supply

Ensure that the 12 V power supply for the instrument is protected by a suitably rated fuse or protective circuit breaker.

SeaTalk systems

Ensure that the power supply for the SeaTalk bus is protected by a 5 A fuse or circuit breaker.

Systems with a large number of instruments on the SeaTalk bus may require connections to the power supply from each end of the system ('ring-main' style), to maintain sufficient voltage throughout the system.

This requirement depends on the total length of the cable run and the total number of instruments in the system, as follows:

Cable run	No. of instruments	Power connections
Up to 10 m	13 maximum	1
	26 maximum	2
Up to 20 m	7 maximum	1
	13 maximum	2

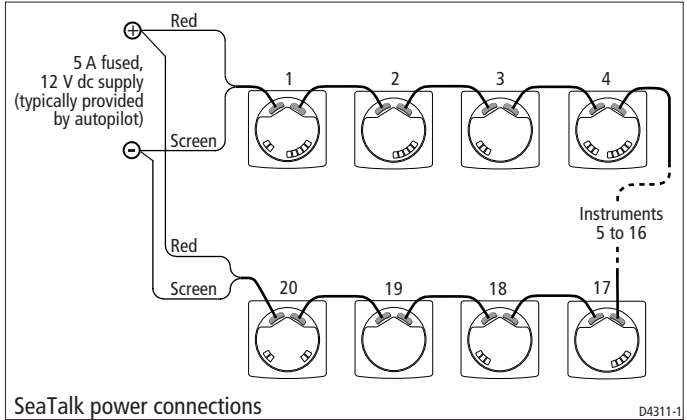

Stand alone instruments

Stand-alone instruments are not connected to SeaTalk and therefore need to be connected to an alternative 12 V power source. Power cables are available in 2 m and 9 m lengths.

To fit a power cable:

1. Ensure the intended power source is switched off.
2. Run the power cable from the instrument to a suitable 12 V dc power source.
3. If the cable has not already been trimmed at the power supply end:
 - i. Cut the cable to length and trim back an appropriate amount of the outer sheath.
 - ii. Cut back and insulate the yellow wire.
4. Connect the screen to the power supply 0 V terminal.
5. Connect the red wire, via a 3 A fuse or protective circuit breaker, to the power supply +12 V terminal.
6. Insert the power cable connector into one of the SeaTalk connectors at the rear of the instrument.

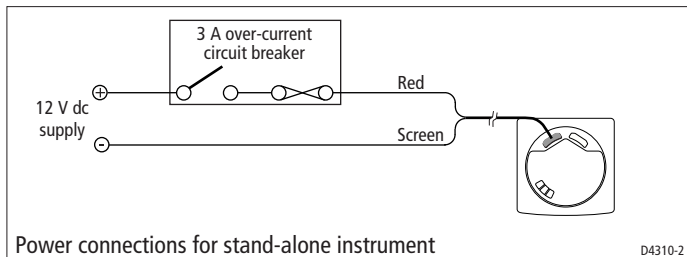

3.3 Switching on

Switch on the power to your ST60+ instrument. When the power is on, you can use the **depth** button to switch the instrument on and off as described in *Chapter 1, Operation*.

Use the procedures in *Chapter 1, Operation* to set the backlighting and contrast how you want them



WARNING: Calibration requirement

To ensure this product performs at its best on your boat, you MUST calibrate it before use, in accordance with the instructions in *Chapter 4, Calibration*. Do NOT use the product until you have successfully calibrated it.

EMC conformance

Always check the installation before going to sea to make sure that it is not affected by radio transmissions, engine starting etc.

Chapter 4: Calibration

4.1 Introduction

The ST60+ Depth instrument is set up with factory-programmed default settings, so in order to optimise the performance of the instrument on board a particular vessel, the procedures in this Chapter must be carried out immediately after the completion of installation, and before the equipment is used for navigational purposes.

Where practicable, the calibration procedures are presented diagrammatically to show the sequence of button presses and the resulting displays. Adjustment instructions are given where applicable.

Note: *The procedure for setting alarm level levels is given in Chapter 1, Operation.*

4.2 User calibration

The User calibration procedures enable you to:

- Set the required units for depth readings.
- Set the offset for depth readings, i.e. determine whether depth readings are from the keel of the vessel or from the water line.
- Lock the shallow alarm.
- Set pop-up pilot display on or off.

To carry out a User calibration:

1. Power up the ST60+ Depth instrument.
2. Hold down the **depth** and **alarm** buttons for approximately 2 seconds so that the User calibration entry screen is displayed.

Note: *The User calibration entry screen will time out to the main display after 7 seconds.*

3. Referring to the *User calibration* diagram, carry out the calibration procedure. Use the **depth** button to cycle from screen to screen and the **offset** and **reset** buttons to set the required values at each screen.

Depth units

Use this screen to select the units in which depth information is displayed. Either FEET, FATHOMS or METRES .

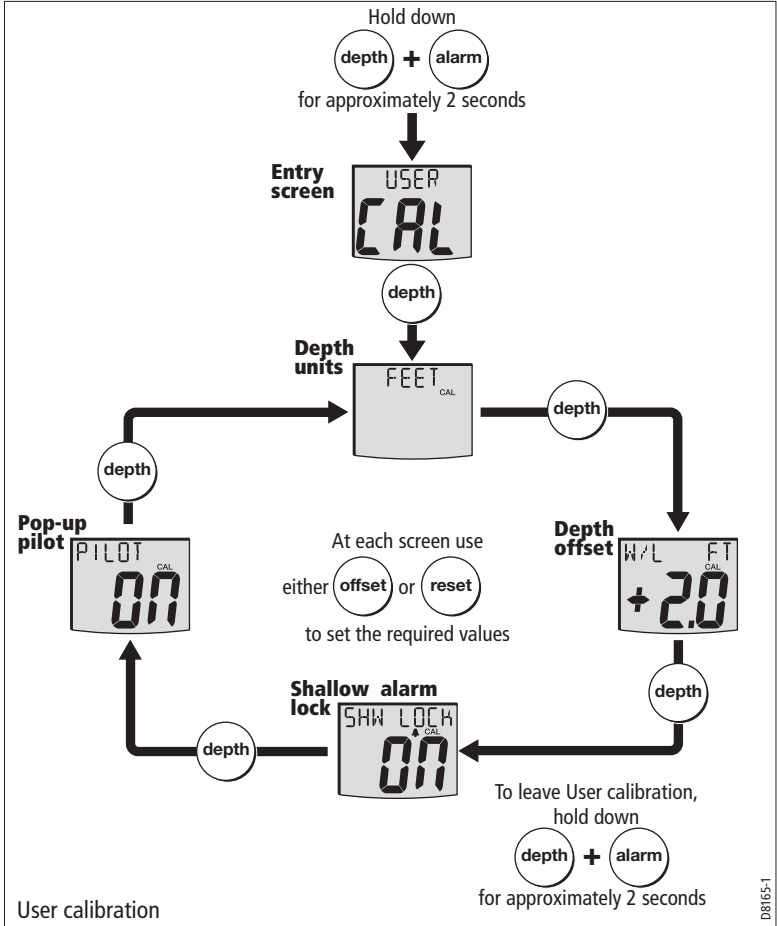

Depth offset

Depths are measured from the transducer to the sea bed. However, you can use the depth offset screen to apply offsets to this distance, so that the displayed depth reading represents either the depth from the keel or the depth from the water line (W/L). In order to do this, you need to know the vertical separation between the transducer position and:

- The bottom of the keel. This requires a negative offset.
- The water line. This requires a positive offset.

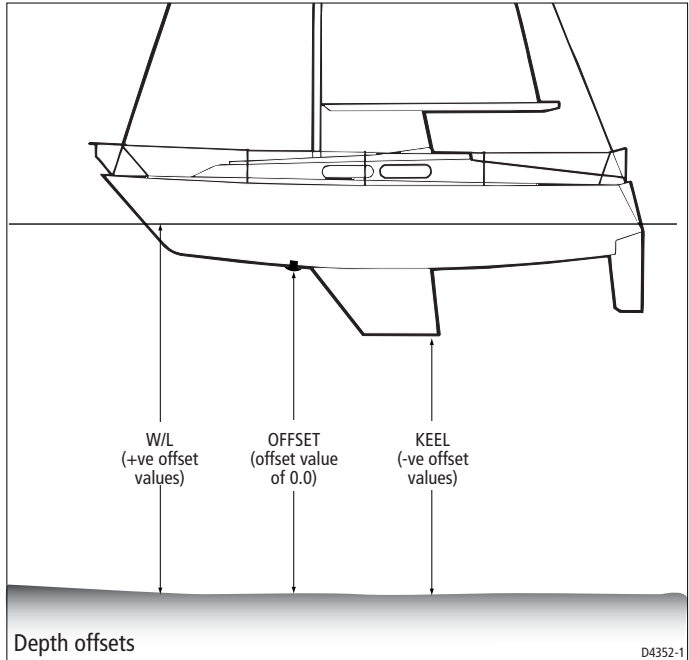

The legend at the top of the Depth offset screen reflects the value you set up, i.e. W/L for positive offsets, KEEL for negative offsets and OFFSET for zero offset.

Setting offset values



WARNING: Use the correct depth offset

The use of the correct depth offset is critical to the safety of the vessel. If incorrect offset values are applied, this could result in misleading depth information being displayed with a consequent risk of running aground. Take great care to ensure you set the correct value.

Use the **offset** (decrement) and **reset** (increment) buttons to set the required offset value.

If you want to display the actual depth reading from the transducer, set a value of 0.0.

If you want to apply a W/L (water line) offset or a KEEL offset, adjust the displayed reading until the correct offset value is shown (positive for W/L ; negative for KEEL).

Shallow alarm lock

When set to On, the shallow alarm lock prevents inadvertent alteration to the shallow depth alarm setting.

Note: *The procedure for setting alarm level levels is given in Chapter 1, Operation.*

Pop-up pilot

Switches the pop-up pilot function on and off.

Leaving User calibration

Hold down the **depth** and **alarm** buttons for 2 seconds to save your settings, exit User calibration and resume normal operation.

4.3 Intermediate calibration

Intermediate calibration enables you to:

- Check the instrument software version.
- Set the instrument status - either **MASTER** or **REPEATER** .

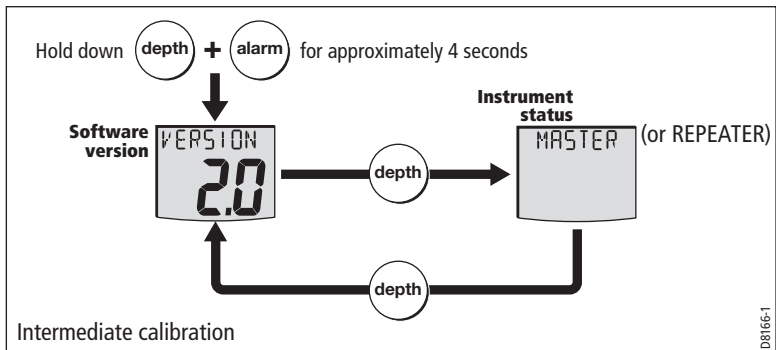

To access the Intermediate calibration screens, hold down the **depth** and **alarm** buttons for approximately 4 seconds. the software version screen is displayed.

To set the instrument status:

1. Press the **depth** button to select the Instrument status screen.
2. Press the **offset** and **reset** buttons simultaneously to enter adjust mode, then press either **offset** or **reset** to set the required status.

Note: *You must not allocate more than one MASTER depth instrument in any system.*

3. Press the **offset** and **reset** buttons simultaneously again, to leave the adjust mode.

Note: *If a fishfinder is connected to the same SeaTalk system as your ST60+ Depth instrument and is switched on, all ST60+ Depth instruments in the system will display fishfinder depth information from SeaTalk. Under these conditions, a master ST60+ Depth instrument will act as a slave, and in Intermediate calibration, the MASTER legend will change to SLAVE, when not in adjust mode.*

Leaving Intermediate calibration

Hold down the **depth** and **alarm** buttons for 2 seconds to save your settings, exit Intermediate calibration and resume normal operation.

4.4 Dealer calibration

The Dealer calibration procedure (see *Dealer calibration* diagram) enables the following parameters to be set:

- User calibration on/off.
- Depth response.
- Boat show mode on/off.

Dealer calibration also gives access to the Factory defaults screen. This enables you to re-apply the factory settings if you want to reset the instrument to a known operating condition.

To commence Dealer calibration, hold down the **depth** and **alarm** buttons together for approximately 12 seconds, to select the Dealer calibration entry page. Press the **offset** and **reset** buttons together, to proceed with the calibration, then use the **depth** button to proceed from screen to screen as calibration progresses.

User calibration on/off

Use either the **offset** button or the **reset** button to switch the User calibration either ON or OFF as required. With OFF selected, User calibration and Intermediate calibration are both disabled. This feature is particularly useful aboard charter vessels, to prevent unwanted alteration of calibration settings.

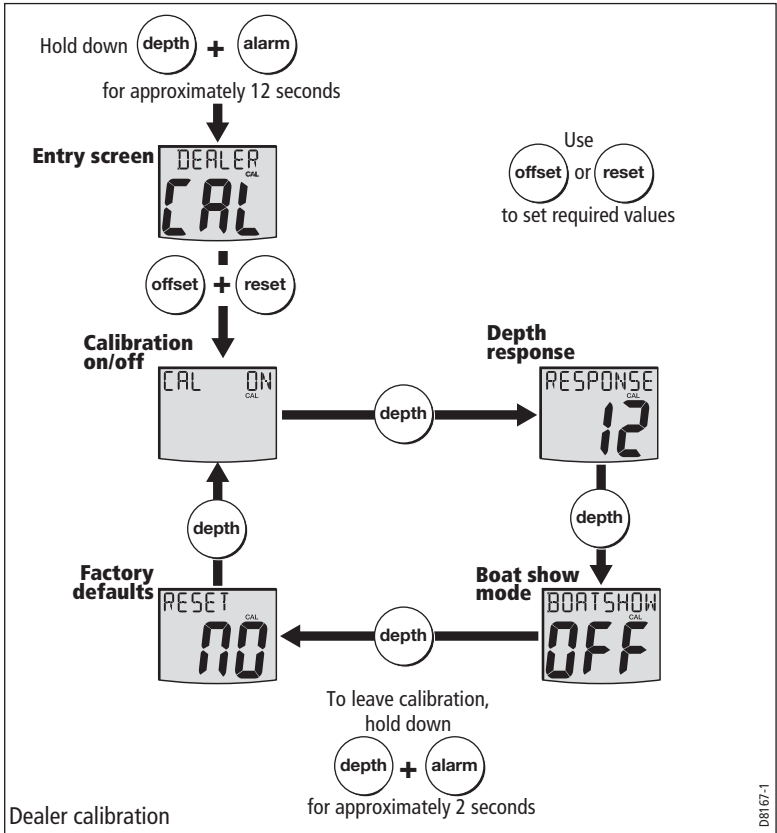

Response settings

The depth response value determines the frequency at which information is updated. A low number provides a smooth response and a high number a much livelier response.

Use the **offset** (decrement) and **reset** (increment) buttons to set the required value. Response values are from 1 to 15.

Boat show mode

CAUTION: Do NOT enable Boat Show Mode

Do NOT enable Boat Show Mode. This must be used only for demonstration purposes.

Ensure that the Boatshow Mode Use is set to OFF . If necessary, use the **offset** or **reset** button to achieve this.

Factory defaults

You can use this screen to reset the operating parameters to the factory default values. Use the **trip** and **reset** buttons to make the required selection.

Note that the selection you make at this screen will be applied when you exit the screen, so be sure you make the correct selection.

To retain the current values, ensure that the display shows NO.

If you want to apply the factory defaults, change the display to YES. If you do this, the values you have set up will be overwritten by the factory defaults when you leave this screen.

Leaving Dealer calibration

Hold down the **depth** and **alarm** buttons for 2 seconds to save your settings, exit Dealer calibration and resume normal operation.

Glossary

APP	Apparent
AVE	Average
AWA	Apparent Wind Angle (relative to the vessel)
AWS	Apparent Wind Speed
BTW	Bearing To Waypoint
CMG	Course Made Good
COG	Course Over Ground
DMG	Distance Made Good
DTW	Distance To Waypoint
EMC	Electro Magnetic Compatibility
ETA	Estimated Time of Arrival
GPS	Global Positioning System
HDG	Heading
KM	Kilometer(s)
KMH	Kilometers per hour
KTS	Knot(s)
LAT	Latitude
LCD	Liquid Crystal Display
LON	Longitude
LTR	Liter(s)

M	Magnetic or meters
MAG	Magnetic
MOB	Man Overboard
MPH	Miles per hour
NM	Nautical mile(s)
Response	The sensitivity of an instrument, to data changes.
RF	Radio Frequency
SeaTalk	Raymarine proprietary communication system which links products, to provide a single, integrated system sharing power and data.
SM	Statute mile(s)
SOG	Speed Over Ground
SPD	Speed
T	True
TTG	Time To Go
TWA	True Wind Angle relative to the vessel, taking into account the speed of the vessel.
TWD	True Wind Direction.
TWS	True Wind Speed.
VMG	Velocity Made Good.
WP	Waypoint
XTE	Cross Track Error

Index

A

Alarms, 3–4

B

Backlighting adjustment, 4
Boat show mode, 33

C

Calibration requirement, 1, 25
Cleaning, 7
Condensation, 7
Contrast adjustment, 5
Current depth, 2

D

Dealer calibration, 31
Depth information, 1
 current depth, 2
 maximum depth, 2
 minimum depth, 2
Depth offset, 4, 29
Display setup, 4
Disposing of the product, ii

E

EMC information, i, 7, 14, 25

F

Factory defaults, 33

H

Help lines, 9

I

Installing
 instrument, 16
 bracket mounting, 20
 flush mounting, 17
 power supply connections, 23
 requirements, 13
 signal connections, 22
 surface mounting, 16
 planning, 11
 transducer, 21
 requirements, 11
 running cable, 21
Instrument mounting options, viii
Intermediate calibration, 30

M

Maximum depth, 2
Minimum depth, 2
Mounting options (instrument), viii, 16

P

Parts supplied, ix–x
Pop-up pilot, 5
Power supply
 SeaTalk systems, 23
 stand alone instrument, 24
Product disposal, ii

R

Remote control, viii, 5

S

Safety
 calibration requirement, 1, 25
 depth offset, 4, 29
 electrical, i
 general, i
 navigation, i
SeaTalk overview, vii
Servicing & safety, 7
Setting up
 applying factory defaults, 33
 backlighting, 4
 contrast, 5
 depth offset, 28, 29
 depth units, 27
 instrument response, 32
 instrument status, 30
 User calibration access, 31
Shallow alarm lock, 30
Site requirements
 instrument, 13
 transducer, 11
Software version, 9, 30
Switching on/off, 1, 25

T

Technical support, 9
Troubleshooting, 8

U

User calibration, 27

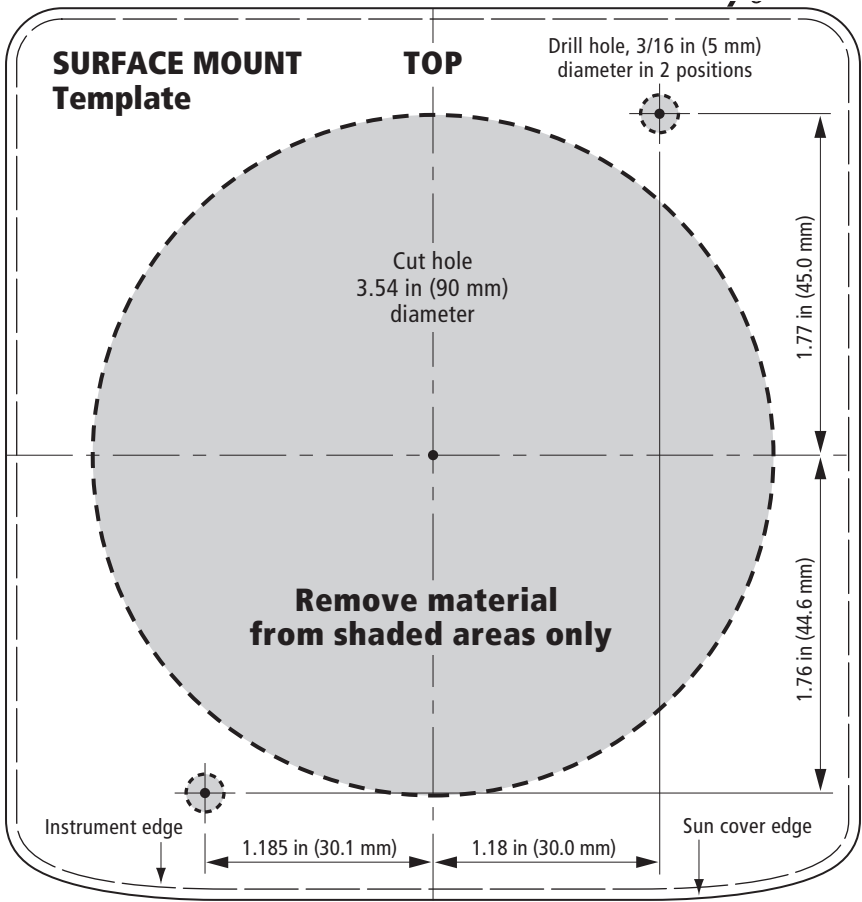

08157-1
PARTS.1

SURFACE MOUNT template for ST60+ Instruments

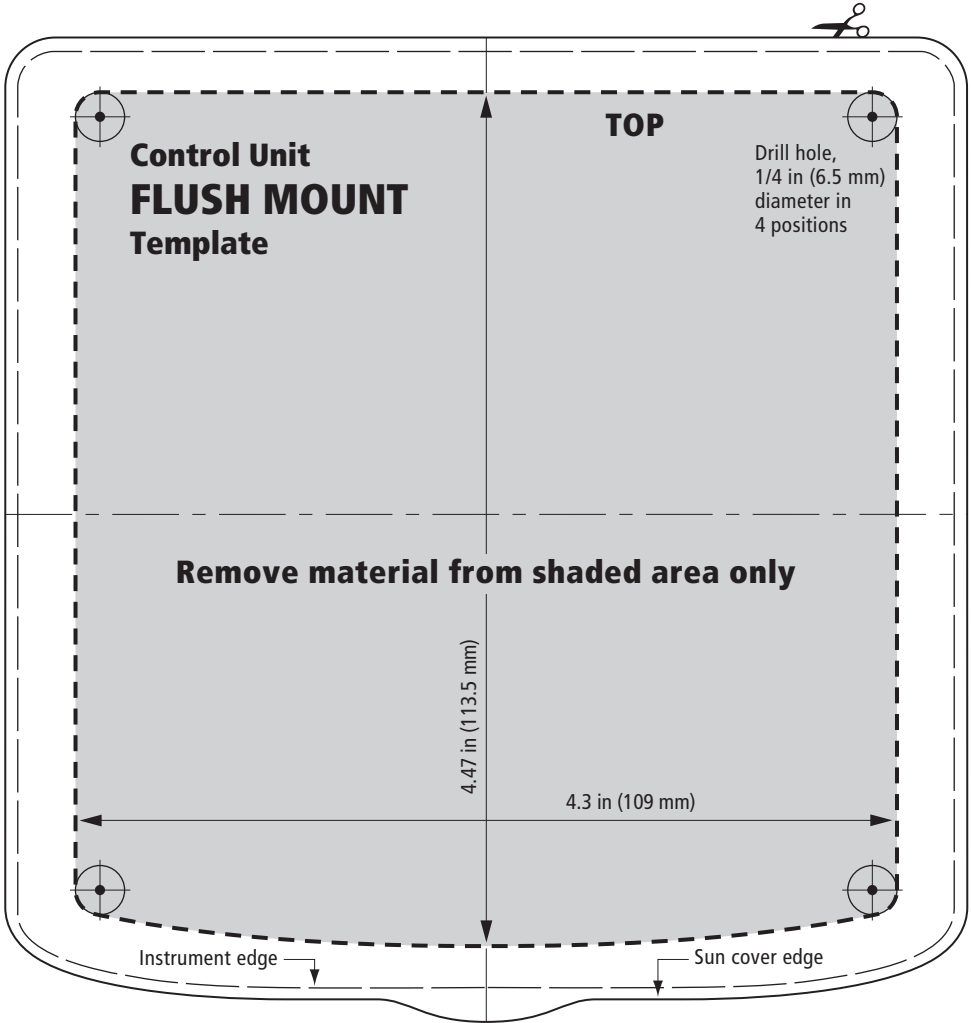

**FLUSH MOUNT template for
ST60+ Instruments**

