

ST60+ Tridata Instrument

Owner's Handbook

Document reference: 81263-2
Date: December 2005

Important information

Safety notices

**WARNING: Product installation & operation**

This equipment must be installed and operated in accordance with the Raymarine instructions provided. Failure to do so could result in personal injury, damage to your boat and/or poor product performance.

**WARNING: Electrical safety**

Make sure you have switched off the power supply before you start installing this product.

**WARNING: Navigational safety**

Although we have designed this product to be accurate and reliable, many factors can affect its performance. Therefore, it should serve only as an aid to navigation and should never replace commonsense and navigational judgement. Always maintain a permanent watch so you can respond to situations as they develop.

EMC conformance

All Raymarine equipment and accessories are designed to the best industry standards for use in the recreational marine environment.

The design and manufacture of Raymarine equipment and accessories conform to the appropriate Electromagnetic Compatibility (EMC) standards, but correct installation is required to ensure that performance is not compromised.

Handbook information

To the best of our knowledge, the information in this handbook was correct when it went to press. However, Raymarine cannot accept liability for any inaccuracies or omissions it may contain.

In addition, our policy of continuous product improvement may change specifications without notice. Therefore, Raymarine cannot accept liability for any differences between the product and the handbook.

Product disposal



Waste Electrical and Electronic (WEEE) Directive

The WEEE Directive requires the recycling of waste electrical and electronic equipment.

Whilst the WEEE Directive does not apply to some of Raymarine's products, we support its policy and ask you to be aware of how to dispose of this product.

The crossed out wheellie bin symbol, illustrated above, and found on our products signifies that this product should not be disposed of in general waste or landfill.

Please contact your local dealer, national distributor or Raymarine Technical Services for information on product disposal.

Contents

Important information	i
Safety notices	i
WARNING: Product installation & operation	i
WARNING: Electrical safety	i
WARNING: Navigational safety	i
EMC conformance	i
Handbook information	i
Product disposal	ii
Contents	iii
Introduction	vii
Data inputs	vii
SeaTalk	vii
Stand alone operation	viii
Remote control	viii
Mounting options	viii
Chapter 1: Operation	1
1.1 Getting started	1
WARNING: Calibration requirement	1
Switching on and off.....	1
Displayed information	1
1.2 Normal operation	2
Depth information	2
Using with fishfinder products	2
Current depth display.....	2
Depth alarm level displays	3
Speed information	4
Boat speed	4
Maximum speed	5
Average speed	5
Velocity made good (to windward).....	5
Distance, temperature & timer information	5
Water temperature.....	6
Timers	6
Log.....	7
Trip screen	8
1.3 Display settings	8
Illumination	8
Contrast.....	8
1.4 Remote control	8

Chapter 2: Maintenance & Troubleshooting 9

 2.1 Maintenance 9

 Servicing and safety 9

 Instrument 9

 Transducers 9

 Cabling..... 10

 2.2 Troubleshooting 10

 Preliminary procedures 10

 Fixing faults..... 10

CAUTION: Prevention of flooding 10

 Technical support 11

 World wide web 11

 Telephone help line..... 11

 Help us to help you 12

Chapter 3: Installation 13

 3.1 Planning your installation 13

 Site requirements 13

 Transducers..... 13

 Instrument..... 15

CAUTION: Keep the rear of the instrument dry 15

 EMC Installation Guidelines..... 16

 Suppression Ferrites 17

 Connections to Other Equipment 17

 3.2 Procedures 18

CAUTION: Maintain structural safety 18

 Unpacking..... 18

 Fitting the instrument..... 18

 Surface mounting 18

 Flush mounting 19

CAUTION: Use the correct screws..... 21

 Bracket mounting..... 22

 Fitting transducer 22

 Running transducer cable..... 23

 Connecting the instrument 24

 Types of connection 24

 Fitting ferrites..... 24

 Signal connections 25

 Power supply connections..... 25

CAUTION: Protect the power supply..... 25

 3.3 Switching on 27

WARNING: Calibration requirement 27

 EMC conformance..... 27

Chapter 4: Calibration	29
4.1 Introduction	29
4.2 User calibration	29
Depth.....	30
Depth units	31
Depth offset	31
WARNING: Use the correct depth offset	32
Shallow alarm lock.....	32
Speed.....	32
Set speed units.....	33
Set speed resolution.....	34
Set log units	34
Setting the correct speed	34
Set temperature units.....	35
Temperature calibration.....	35
Timer alarm buzzer	35
Leaving User calibration	35
4.3 Intermediate calibration	35
Speed calibration.....	36
Leaving Intermediate calibration	39
4.4 Dealer calibration	39
User calibration on/off	39
Speed select (SOG on/off)	40
Response settings.....	41
Boat show mode.....	41
CAUTION: Do NOT enable Boat Show Mode	41
Factory defaults	41
Leaving Dealer calibration	41
Glossary	43
Index	45

Introduction

Thank you for purchasing a Raymarine product. We are sure your ST60+ instrument will give you many years of trouble-free operation.

This handbook describes how to install and use the Raymarine ST60+ Tridata instrument. This instrument provides accurate depth, speed, trip and timer information, on a high quality Liquid Crystal Display (LCD). The instrument is constructed in a rugged weather-proofed case to provide reliable performance, even under the most demanding conditions.

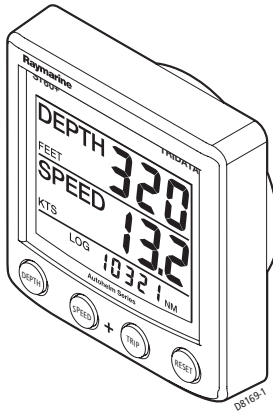

Data inputs

The ST60+ Tridata instrument can fulfil master and/or repeater roles by receiving data either from the appropriate transducers and/or from a SeaTalk instrumentation system.

SeaTalk

SeaTalk enables a number of compatible instruments to operate as a single, integrated navigational system. Instruments in a SeaTalk system are linked by means of a single cable, which feeds both power and data. Instruments can therefore be added to the system by plugging them into the network. SeaTalk is flexible enough to adapt to any number of compatible instruments without requiring a central processor. SeaTalk can also communicate via an interface, with non-SeaTalk equipment using the internationally-accepted National Marine Electronics Association (NMEA) protocol.

In a SeaTalk system, each instrument can be either a master or dedicated repeater unit. A master instrument is directly connected to a transducer (the device that provides the raw data), and provides data and control appropriate to its function, to all other equipment on the SeaTalk network. A repeater instrument is not directly connected to a transducer but displays information provided by other equipment in the SeaTalk network.

Stand alone operation

In Stand alone operation, the ST60+ Tridata instrument is connected only to the relevant transducer and does not display information from, or provide information to, any other instruments.

Remote control

When connected to SeaTalk, the ST60+ Tridata instrument can be controlled remotely by a SeaTalk Remote Keypad Unit, to provide instant remote access to the various display readouts.

Mounting options

A standard ST60+ instrument is surface-mounted at the required location. If you do not want to surface mount your ST60+ instrument, options are available for:

- Flush mounting. If you have ordered the flush mounting option a flush mount bezel and four fixing screws are also provided.
- Bracket mounting.

Parts supplied

Unpack your ST60+ instrument and check that the following items are present:

- Item 1, ST60+ Tridata instrument fitted with standard bezel for surface mounting.
- Item 2, Fixing studs (2).
- Item 3, Thumb nuts (2).
- Item 4, Gasket.
- Item 5, Depth transducer.
- Item 6, Speed transducer, plus bung (not illustrated).
- Item 7, SeaTalk interconnection cable.
- Item 8, Power cable.
- Item 9, Instrument Cover.
- Item 10, Owner's Handbook. A Warranty document and fitting templates are included in this Handbook.
- Item 11, Cue Card.

Spare spade terminals are also provided, to re-terminate the transducer cable if it has to be cut to facilitate installation.

Note: *The above packing list is for an ST60+ Tridata system. Where an instrument is purchased separately, Speed and Depth transducers are not included.*

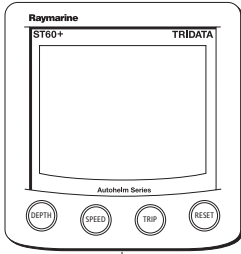

1

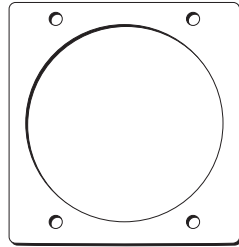

4

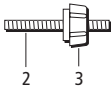

2

3

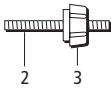

2

3

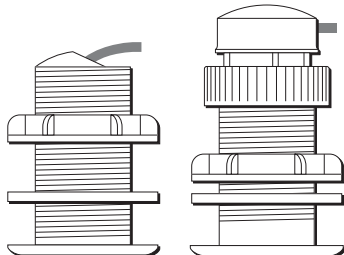

5

6



9



7



8

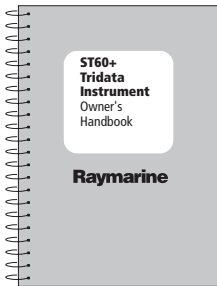

10

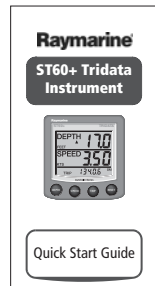

11

Chapter 1: Operation

1.1 Getting started

This handbook describes how to operate, maintain and install the Raymarine ST60+ Tridata instrument.



WARNING: Calibration requirement

To ensure this product performs at its best on your boat, you MUST calibrate it before use, in accordance with the instructions in *Chapter 4, Calibration*. Do NOT use the product until you have successfully calibrated it.

Switching on and off

All the time that power is applied to the instrument, you can use the **depth** button to switch the instrument off and on as follows:

- To switch the instrument off, hold down the **depth** button for approximately 5 seconds. After this time, a switch off count down of 4 seconds occurs. Keep the **depth** button pressed during this period, to switch off the instrument.
- To switch the instrument back on, hold down the **depth** button for approximately 1 second.

When the power supply is switched off, none of the instrument buttons (including **depth**) has any effect.

- Notes:**
- (1) *Each time power to the instrument is switched on, the instrument is initially in the on condition. You do not need to use the **depth** button to switch the instrument on.*
 - (2) *When the instrument is on, the operation of the **depth** button will perform other operating functions, as described below.*

Displayed information

The ST60+ Tridata instrument screen is divided into three separate areas, each of which displays a separate type of information, as shown in the following illustration.

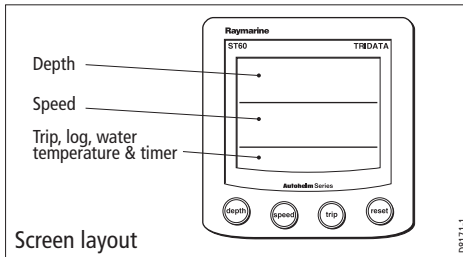

1.2 Normal operation

Use the flow charts in this Chapter to operate your ST60+ Tridata instrument. Flow charts are provided for:

- Using the **depth** button. This gives access to current depth information. On master instruments, this also gives access to depth alarm level information, and allows you to set the alarm levels.
- Using the **speed** button. This gives access to maximum speed, average speed and Velocity Made Good (VMG) to windward.
- Using the **trip** button to gain access to log, trip, water temperature and timer information.

All button presses are momentary unless otherwise stated.

Depth information

Use the **depth** button to select the required information, as shown in the *Using the depth button* illustration. The depth measurement units are either feet or metres, as selected during user calibration (see *Chapter 4, Calibration*).

Using with fishfinder products

Depth information is normally obtained from the Depth transducer, fitted as part of an ST60+ Depth or Tridata system. However, when the ST60+ Tridata instrument is connected to a SeaTalk system, to which a compatible fishfinder is also connected, the depth information is provided by the fishfinder all the time the fishfinder is switched on.

Current depth display

The current depth screen shows the title DEPTH, the selected depth units and the depth measurement. It also shows a depth trend indicator, which is either an up arrow to show seabed rising or a down arrow to show seabed falling.

If for any reason depth information is lost, the DEPTH title will flash once per second and the displayed depth value will be the last good reading.

Depth alarm level displays

Alarm displays are available if the instrument is operating as a master. Each display is identified by the presence of an alarm symbol (▲) and either an up depth trend arrow ▲ for a shallow alarm or a down depth trend arrow ▼ for a deep alarm. The shallow and deep anchor alarms are identified by means of an additional anchor symbol (⚓).

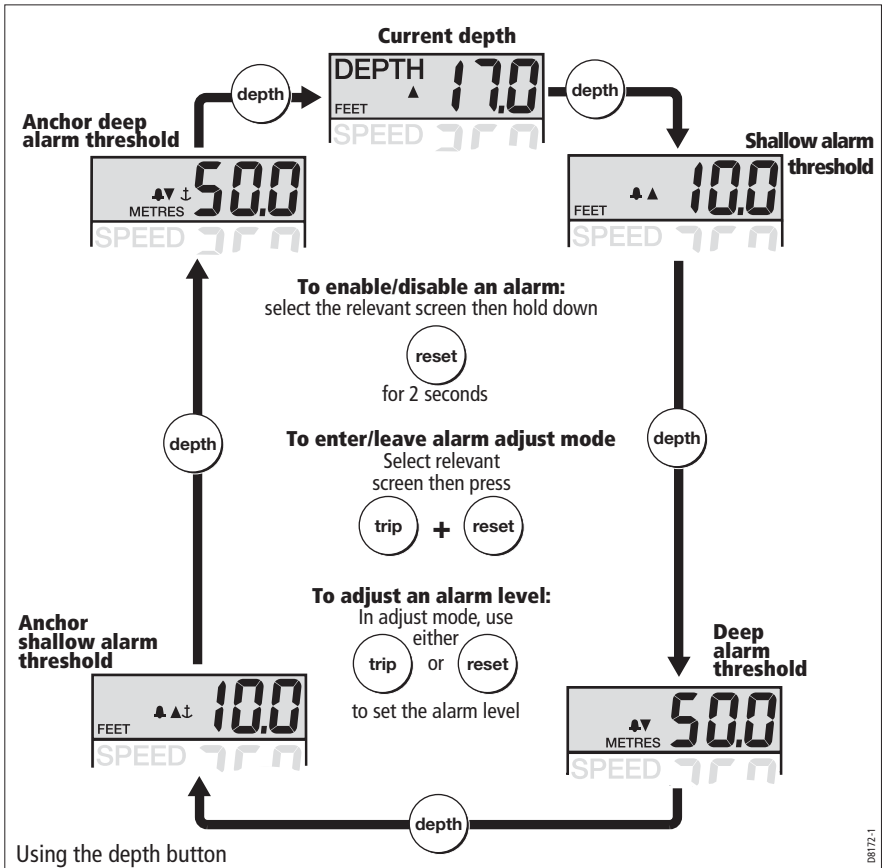

You can enable and disable individual alarms by pressing the **reset** button for 2 seconds, while the relevant alarm screen is displayed.

Each alarm screen is displayed for a nominal 7 seconds, and if no action is taken during that time, the display will timeout to the current depth display.

An alarm condition occurs if:

- The depth is less than the **SHALLOW** or **SHALLOW** anchor level.
- The depth is greater than the **DEEP** anchor level.
- The depth crosses the **DEEP** level.

An alarm condition is indicated by an alarm buzzer and a flashing alarm symbol (▲) on the display. **SHALLOW** or **DEEP** alarms are indicated by up and down arrows respectively, and for anchor alarms, the anchor symbol (⚓) is displayed.

When the instrument is operating as a master, you can check the alarm levels and if necessary set them up. If an alarm is not enabled, the associated display shows an **OFF** legend.

Adjusting alarm levels

To adjust the alarm levels:

1. Use the **depth** button to display the alarm screen you want to adjust
2. Press the **trip** and **reset** buttons simultaneously to enter adjust mode, then use either the **trip** button (to decrease) or the **reset** button (to increase) the level.
3. When you have set the required value, press the **trip** and **reset** buttons again, to save the alarm setting and exit the adjust mode.

Note: *Adjustment of the shallow alarm level can be disabled during calibration. If adjustment is disabled, you cannot enter adjust mode.*

Speed information

Use the **speed** button to select the required information, as shown in the *Using the speed button* illustration. The speed measurement units are either knots (KTS), miles per hour (MPH) or kilometres per hour (KMH), as selected during user calibration (see *Chapter 4, Calibration*).

The maximum speed, average speed and VMG to windward are each displayed for 7 seconds, and if no action is taken during that time, the display will timeout to the Boat speed display.

Boat speed

Shows the current speed and selected speed units. The speed information is obtained either from a speed transducer, or derived from Speed Over Ground (SOG). SOG is available if you are connected to a SeaTalk system to which a compatible GPS is also connected.

The source of speed information (transducer or SOG) is selected during Dealer calibration (see *Chapter 4, Calibration*).

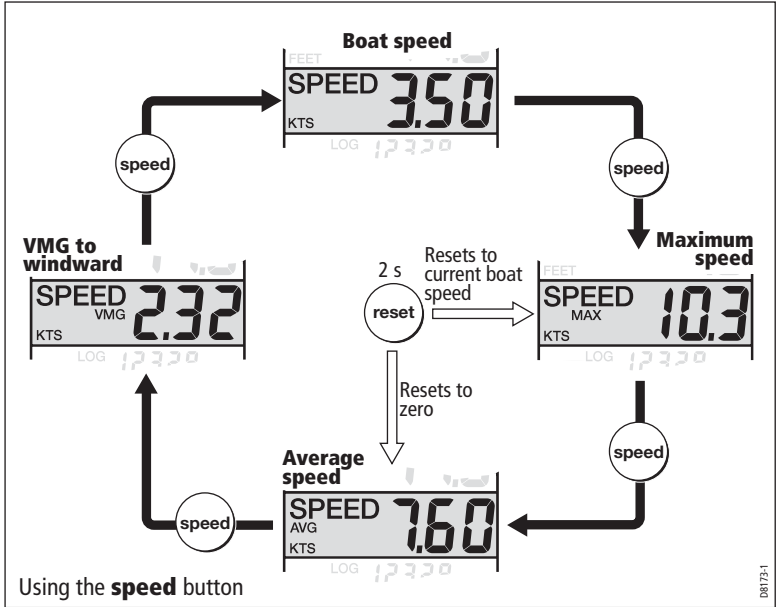

Maximum speed

The screen shows the maximum speed attained since the last reset.

The maximum speed value is reset automatically at power-up. If the instrument is operating as a master, the maximum speed can also be reset manually by pressing the **reset** button for 2 seconds.

Average speed

The screen shows the average speed since the last reset.

The average speed value is reset automatically at power-up. If the instrument is operating as a master, the average speed can also be reset manually by pressing the **reset** button for 2 seconds.

Velocity made good (to windward)

Velocity made good (VMG) information is available if your instrument is part of a SeaTalk system to which a SeaTalk-compatible wind instrument is also connected.

Distance, temperature & timer information

The **trip** button gives access to log, trip, water temperature and timer displays, as shown in the *Using the trip button* illustration.

Water temperature

The water temperature is shown in either degrees Celsius (°C) or Fahrenheit (°F), as set during calibration (see *Chapter 4, Calibration*).

Timers

The count-up timer and the two race-start timer times are either in seconds (S) or minutes (M), depending on the counter values.

Refer to the *Using the trip button* flow diagram to display the required timer. Once you have done this, press the **reset** button to start the timer running. When a timer is running, the delimiter (. or :) flashes. When a timer is running, press the **reset** button for lap times. To stop a timer, press the **reset** button.

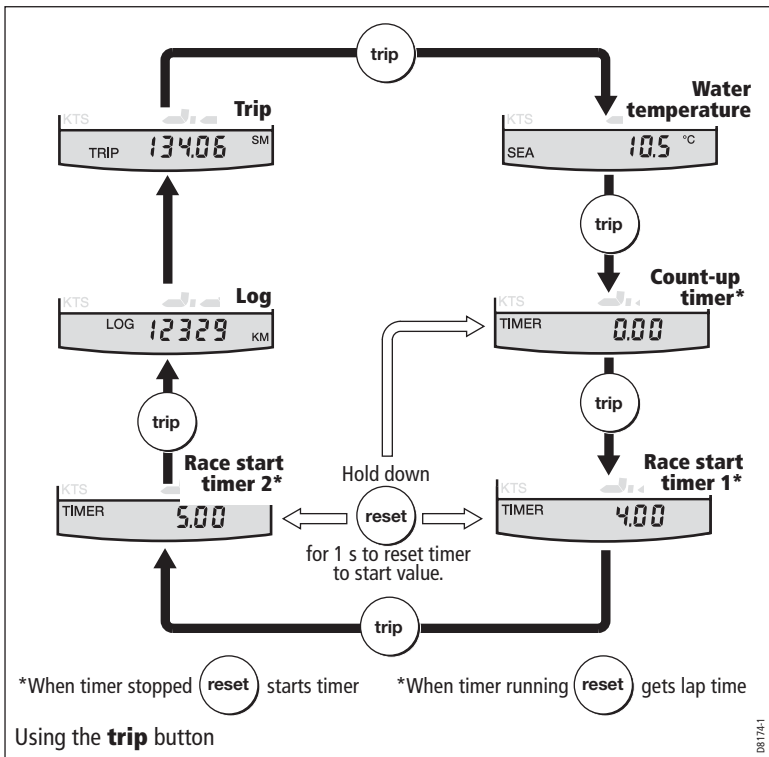

To reset a timer to the start value, stop it then hold down the **reset** button for 1 second.

Once a timer is running, you can leave the timer page and select any other display. The counter will continue to run in the background.

Race-start timers

You can set each race-start timer to any whole-minute value from 1 to 15 minutes.

Note: *When the instrument is first installed, the race-start timers are set to 4 and 5 minutes respectively.*

To set a race-start timer:

1. Use the **trip** button as shown in the *Using trip button* flow diagram to select the required race-start timer.
2. Simultaneously press the **trip** and **reset** buttons to enter the race-start timer adjust mode.
3. Use either the **trip** or **reset** button to set the required value.
4. Simultaneously press the **trip** and **reset** buttons to save the value and leave the race-start timer adjust mode.

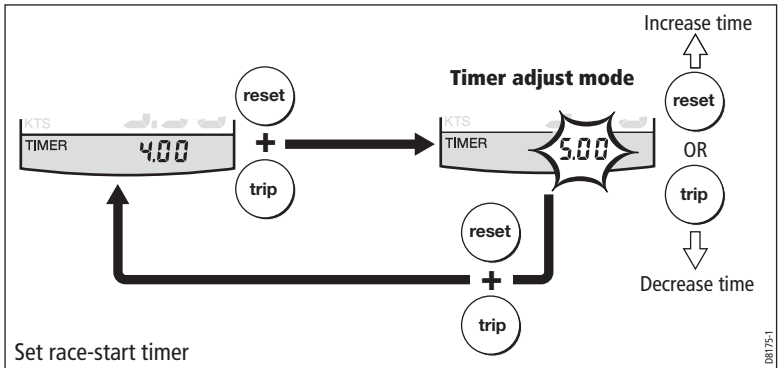

If you are using one of the race-start timers and the timer buzzer is enabled, the buzzer will:

- Double-beep every minute.
- Beep three times at the start of the last 30 seconds.
- Beep once for each of the last 10 seconds.
- Beep for 2 seconds at zero.

The timer buzzer is enabled or disabled as part of the calibration procedure (see *Chapter 4, Calibration*).

Note: *After a race-start timer has counted-down to zero, it will then start counting up.*

Log

The Log screen shows the total distance covered by the vessel since the instrument was fitted.

Trip screen

The trip screen shows the distance covered since the trip value was last reset.

The trip value is reset automatically at power-up, and if the instrument is operating as a master, the trip value can also be reset manually by pressing the **reset** button for 3 seconds.

1.3 Display settings

Illumination

When the instrument is first powered up, the display illumination is set to its lowest (courtesy) level, to facilitate initial access to the buttons.

To adjust the level of display illumination:

1. Hold down the **depth** button for approximately one second, to enter the illumination-adjust mode.
2. There are four preset illumination levels. Use the **depth** button to cycle through these levels until you reach the level you want.
3. Press any other button to leave the illumination-adjust mode.

Note: *The display will also return to normal operation 7 seconds after the last button press.*

Contrast

To adjust the display contrast:

1. Hold down the **depth** button for approximately two seconds, to enter the contrast-adjust mode.
2. There are four preset contrast settings. Use the **depth** button to cycle through these settings until you achieve optimum display quality.
3. Press any other button to leave the contrast-adjust mode.

Note: *The display will also return to normal operation 7 seconds after the last button press.*

1.4 Remote control

When it is connected to SeaTalk, the ST60+ Tridata instrument can be controlled remotely with a SeaTalk Remote Keypad Unit. Remote control of an instrument is indicated by a REMOTE legend on the display, to indicate that the button pad has control.

Details on how to use the remote control facility are given in the *SeaTalk Remote Keypad Owner's Handbook*.

Chapter 2: Maintenance & Troubleshooting

2.1 Maintenance

Servicing and safety

- Raymarine equipment should be serviced only by authorised Raymarine service technicians. They will ensure that servicing procedures and replacement parts used will not affect performance. There are no user-serviceable parts in any Raymarine product.
- Some products generate high voltages, and so never handle the cables/connectors when power is being applied to the equipment.
- When powered up, all electrical equipment produces electromagnetic fields. These can cause adjacent pieces of electrical equipment to interact with one another, with a consequent adverse effect on operation. In order to minimise these effects and enable you to get the best possible performance from your Raymarine equipment, guidelines are given in the installation instructions, to enable you to ensure minimum interaction between different items of equipment, i.e. ensure optimum Electromagnetic Compatibility (EMC).
- Always report any EMC-related problem to your nearest Raymarine dealer. We use such information to improve our quality standards.
- In some installations, it may not be possible to prevent the equipment from being affected by external influences. In general this will not damage the equipment but it can lead to spurious resetting action, or momentarily may result in faulty operation.

Instrument

Certain atmospheric conditions may cause condensation to form on the instrument window. This will not harm the instrument and can be cleared by increasing the illumination setting to Level 3.

Periodically clean your ST60+ instrument with a soft damp cloth. Do NOT use chemical and abrasive materials to clean the instrument.

Transducers

Refer to the Installation and Maintenance instructions supplied with the transducers.

Cabling

Examine all cables for chafing or other damage to the outer shield, and where necessary, replace and re-secure.

2.2 Troubleshooting

Preliminary procedures

Changes in the electronic environment may adversely affect the operation of your ST60+ equipment. Typical examples of such changes are:

- Electrical equipment has recently been installed or moved aboard your vessel.
- You are in the vicinity of another vessel or shore station emitting radio signals.

If you appear to have a problem, first ensure that the EMC requirements (see *Chapter 3, Installation*) are still being met before further investigating the problem.

Fixing faults

CAUTION: Prevention of flooding

If you need to remove the transducer insert, have the transducer bung to hand and secure it in the transducer body immediately after the insert has been removed, to prevent excessive ingress of water.

All Raymarine products are subjected to comprehensive test and quality assurance programmes prior to packing and shipping. However, if a fault occurs, the following table may help to identify and rectify the problem.

Fault	Cause	Remedy
Instrument display blank.	No power supply.	Check power supply. Check SeaTalk cabling and connector security. Check fuse/circuit breaker.
No speed or temperature information.	Speed transducer cabling problem.	Check cabling and security of transducer connections.
No speed information.	Speed transducer paddle wheel fouled.	Clean paddle wheel. See CAUTION below.

Fault	Cause	Remedy
No exchange of information between SeaTalk instruments.	SeaTalk cabling problem.	Check the security of SeaTalk connectors. Disconnect instruments one by one, to isolate faulty unit.
Failure of group of instruments in SeaTalk chain.	SeaTalk cabling or connector problem.	Check the security of SeaTalk connections between functioning and non-functioning instruments.
LAST flashes or dashes displayed continuously (depth greater than 3 feet).	Depth transducer or connection problem.	Check depth transducer cable and security of transducer connections.
LAST flashes while under way.	Aerated water Boat wake Prop wash etc	Ensure readings stabilise when clear of disturbed water.

Technical support

Raymarine provides a comprehensive customer support service, on the world wide web and by telephone help line. Please use either of these facilities if you are unable to rectify a problem.

World wide web

Please visit the Customer Support area of our web site at:

www.raymarine.com

As well as providing a comprehensive Frequently Asked Questions section and servicing information, it also gives e-mail access to the Raymarine Technical Support Department and a details of the locations of Raymarine agents, worldwide.

Telephone help line

If you do not have access to the world wide web, please call:

- 1-800-539-5539, extension 2444 or
- (603) 881-5200 extension 2444

Help us to help you

When requesting service, please quote the following product information:

- Equipment type.
- Model number.
- Serial number.
- Software issue number.

To find out the software version number of your ST60+ Tridata instrument:

1. During normal operation, hold down the **depth** and **speed** buttons for approximately 4 seconds, to display the software version (VEr) screen.

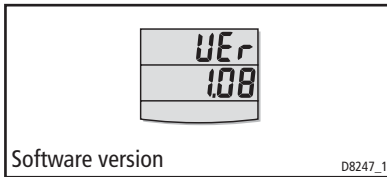

2. Note the software version number, then hold down the **depth** and **speed** buttons for approximately 2 seconds, to return to normal operation.

Chapter 3: Installation

This chapter describes how to install the ST60+ Tridata instrument, and associated Speed and Depth transducers. The transducers are fitted in the hull of the vessel and connected to the rear of the instrument. The actual type of transducers depends on the type of hull in which they are to be installed.

For advice, or further information regarding the installation of this equipment, please contact the Raymarine Product Support Department or your own National Distributor.

3.1 Planning your installation

Before starting the installation, spend some time considering the best positions for both transducer and instrument, such that the *Site Requirements* and the *EMC Guidelines* (below) are satisfied.

Site requirements

Transducers

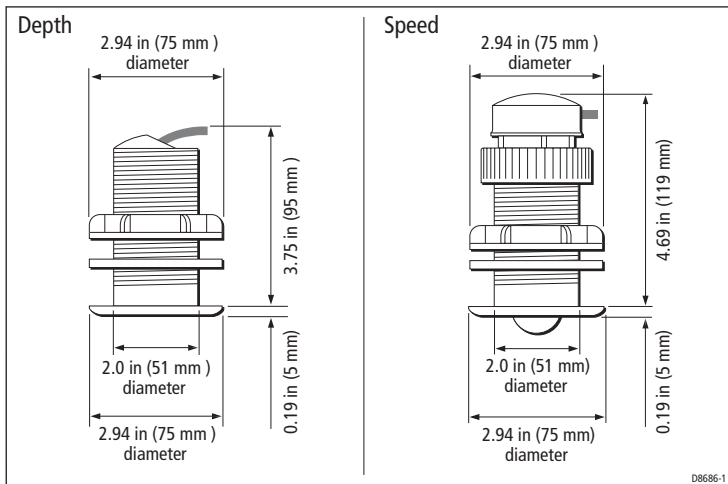

The transducer types required for the various hull types are as follows:

Hull material	Speed transducer	Depth transducer
Glass reinforced plastic (GRP)	E26031 Through hull plastic	31-188-4-02 Through hull plastic or M78718 Retractable through hull
Steel	E26031 Through hull plastic	31-188-4-02 Through hull plastic or M78718 Retractable through hull
Aluminium	E26031 Through hull plastic	31-188-4-02 Through hull plastic or M78718 Retractable through hull
Wood	M78716 Through hull bronze	M78714 Through hull bronze or M78719 Retractable through hull bronze

Other transducer types are also available for specific requirements. For further details, contact your local Raymarine dealer.

For accurate speed and depth readings the transducers should be sited within the clear water flow areas indicated by the shaded areas in the following diagram.

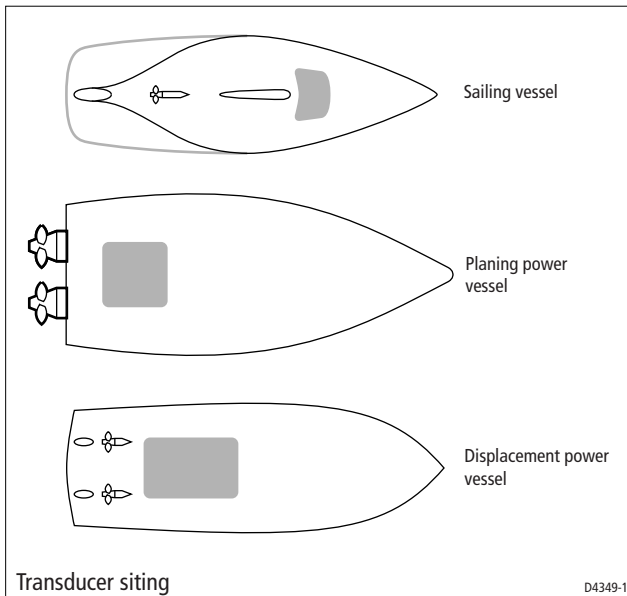

The transducers should also:

- Be ahead of the propellers (by a minimum of 10% of the water line length).
- Be at least 150 mm (6 in) away from the keel (ideally ahead of the keel if a sailing yacht).
- Be as near as possible to the centre line of the vessel.
- Be clear of other through-hull fittings or projections.
- Have sufficient clearance inside the hull to fit the nut.
- Have 100 mm (4 in) of headroom to allow for withdrawal.

In addition to the above requirements, the depth transducer must be mounted within 10° of the vertical, forward, aft and athwartships.

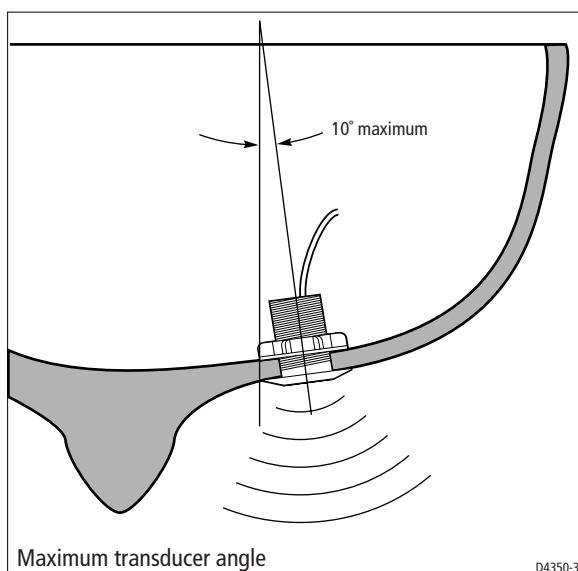

Instrument

CAUTION: Keep the rear of the instrument dry

Keep the rear of instrument dry. Failure to observe this caution could result in damage if water enters the instrument through the breathing hole or comes into contact with the electrical connectors.

ST60+ instruments can be fitted either above or below deck, provided the rear of the instrument is sited where it is protected from contact with water.

Each instrument must also be positioned where:

- It is easily read by the helmsman
- It is protected against physical damage
- It is at least 230 mm (9 in) from a compass
- It is at least 500 mm (20 in) from radio receiving equipment
- There is reasonable rear access for installation and servicing

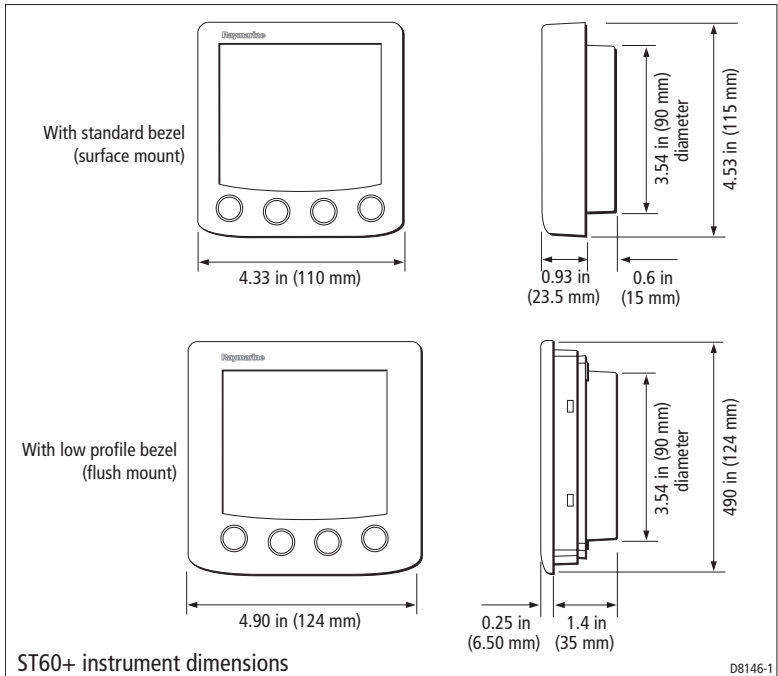

EMC Installation Guidelines

All Raymarine equipment and accessories are designed to the best industry standards for use in the recreational marine environment.

Their design and manufacture conforms to the appropriate Electromagnetic Compatibility (EMC) standards, but correct installation is required to ensure that performance is not compromised. Although every effort has been taken to ensure that they will perform under all conditions, it is important to understand what factors could affect the operation of the product.

The guidelines given here describe the conditions for optimum EMC performance, but it is recognized that it may not be possible to meet all of these conditions in all situations. To ensure the best possible conditions for EMC performance within the

constraints imposed by any location, always ensure the maximum separation possible between different items of electrical equipment.

For **optimum** EMC performance, it is recommended that **wherever possible**:

- Raymarine equipment and cables connected to it are:
 - At least 3 ft (1 m) from any equipment transmitting or cables carrying radio signals e.g. VHF radios, cables and antennas. In the case of SSB radios, the distance should be increased to 7 ft (2 m).
 - More than 7 ft (2 m) from the path of a radar beam. A radar beam can normally be assumed to spread 20 degrees above and below the radiating element.
- The equipment is supplied from a separate battery from that used for engine start. Voltage drops below 10 V in the power supply to our products, and starter motor transients, can cause the equipment to reset. This will not damage the equipment, but may cause the loss of some information and may change the operating mode.
- Raymarine specified cables are used. Cutting and rejoining these cables can compromise EMC performance and must be avoided unless doing so is detailed in the installation manual.
- If a suppression ferrite is attached to a cable, this ferrite should not be removed. If the ferrite needs to be removed during installation it must be reassembled in the same position.

Suppression Ferrites

The following illustration shows typical cable suppression ferrites used with Raymarine equipment. Always use the ferrites supplied by Raymarine.

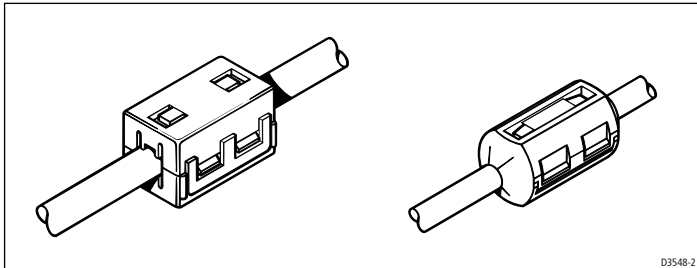

Connections to Other Equipment

If your Raymarine equipment is to be connected to other equipment using a cable not supplied by Raymarine, a suppression ferrite **MUST** always be attached to the cable near the Raymarine unit.

3.2 Procedures

As it is not practical to describe procedures for all possible installation scenarios, the procedures given here describe the broad requirements for installing the Speed and Depth transducers and the ST60+ Tridata instrument. Adapt these procedures as appropriate, to suit your individual requirement.

CAUTION: Maintain structural safety

Where it is necessary to cut holes (e.g. for cable routing and instrument mounting), ensure that these will not cause a hazard by weakening critical parts of the vessel's structure.

Unpacking

Unpack your ST60+ equipment and check that the items described in *Introduction* are present.

Each ST60+ instrument is supplied with a standard bezel for surface mounting. Optional mounting kits are available for flush mounting and bracket mounting the instrument. If you have ordered the flush mounting option a flush mount bezel and four fixing screws are also provided.

Fitting the instrument

The ST60+ Tridata instrument can be installed using one of a number of different mounting options:

- Surface mounting. Gives a profile of approximately 24 mm.
- Flush mounting. Gives a profile of approximately 6 mm.
- Bracket mounting.

The ST60+ instruments can also be mounted behind a panel with just the instrument dial and buttons visible.

Surface mounting

To surface mount your ST60+ instrument (see the *Surface mounting* illustration):

1. Ensure that:
 - The selected location is clean, smooth and flat.
 - There is sufficient space behind the selected location to accommodate the rear of the instrument and connectors.

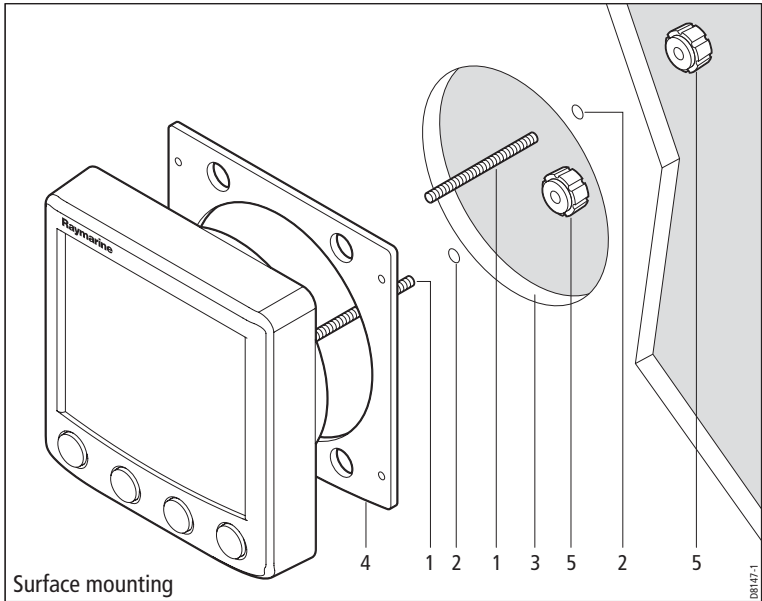

2. Apply the surface mount template (supplied at the rear of this handbook) to the selected location and mark the centres for the fixing studs (1) and the aperture (3) that will take the rear casing of the instrument.
3. Drill out the two 5 mm fixing stud clearance holes (2).
4. Cut out the clearance hole (3) then remove the template.
5. Peel off the protective sheet from the self-adhesive gasket (4) then stick the gasket into position on the rear of the instrument.
6. Screw the two fixing studs into the threaded sockets on the rear of the instrument.
7. Mount the assembled instrument, studs, bezel and gasket into the panel. Secure from behind with the thumb nuts (5).

Flush mounting

The Flush Mounting Kit uses a flush mount bezel to reduce the fitted profile of the instrument, to approximately 0.25 in (6 mm) above the panel fascia.

Fitting the flush mount bezel

In order to flush-mount your ST60+ instrument, you must first replace the standard bezel with the flush mount bezel as follows:

1. Hold the instrument in both hands with the display towards you.

- Using both thumbs, gently press an upper corner of the instrument from the bezel, then remove the bezel from the instrument. Retain the rubber keypad which is released when the bezel is removed.

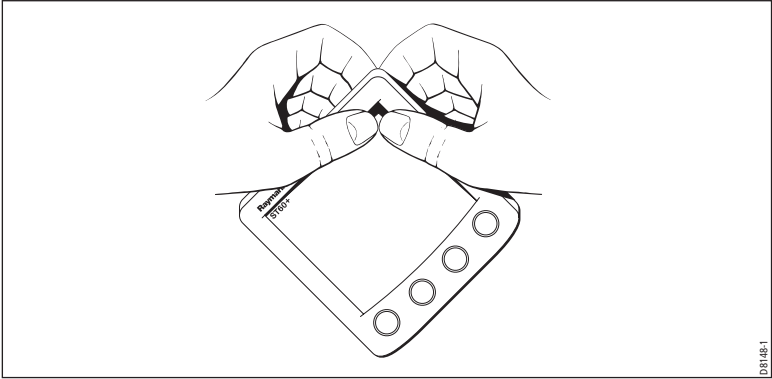

- Referring to the *Fitting the flush mount bezel* illustration, insert the panel seal (8) in the corresponding recess on the back of the flush mount bezel (7).

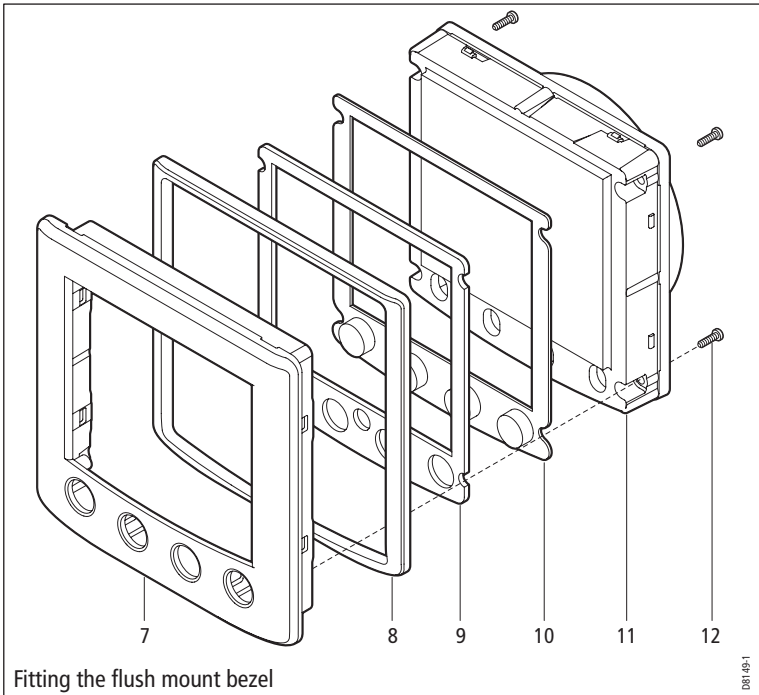

4. Place the instrument (11) face upwards on a flat surface, then place the rubber keypad (10) in position around the display window (i.e. so that each button outline is located over its associated button on the instrument).
5. Place the keypad seal (9) in position on the keypad (i.e. so that the holes in the seal accept the appropriate keypad buttons).
6. Place the assembled flush mount bezel and panel seal, in position on the instrument, so that the rubber keys are correctly located in the holes on the bezel, then clip the bezel and instrument together.

CAUTION: Use the correct screws

It is essential that only screws of the correct size are used to secure the instrument to the bezel. Failure to observe this caution could result in damage to both the instrument and the bezel.

7. Using the four, self-tapping screws (12) provided, secure the instrument and bezel together. Fit the screws from the rear of the instrument and tighten them sufficiently to secure the instrument and bezel together. **DO NOT OVERTIGHTEN.**

Flush mounting procedure

Flush mount your instrument (see the *Flush mounting* illustration) as follows:

1. Assemble the ST60+ instrument and flush mount bezel as described under *Fitting the flush mount bezel*.
2. Ensure that:
 - The panel on which you intend to mount the instrument is between 3 mm and 20 mm thickness.
 - The selected location is clean, smooth and flat.
 - There is sufficient space behind the selected location to accommodate the rear of the instrument and connectors.
3. Apply the flush mount template (supplied at the rear of this handbook) to the selected location and mark out the aperture into which the assembled instrument and bezel will sit.
4. Cut out the aperture (3) for the assembled instrument and bezel and remove the template.
5. Peel off the protective sheet from the self-adhesive gasket (4) then stick the gasket into position on the rear of the bezel.
6. Screw the two fixing studs (1) into the threaded sockets on the rear of the instrument.
7. Mount the assembled instrument, studs, bezel and gasket into the panel.

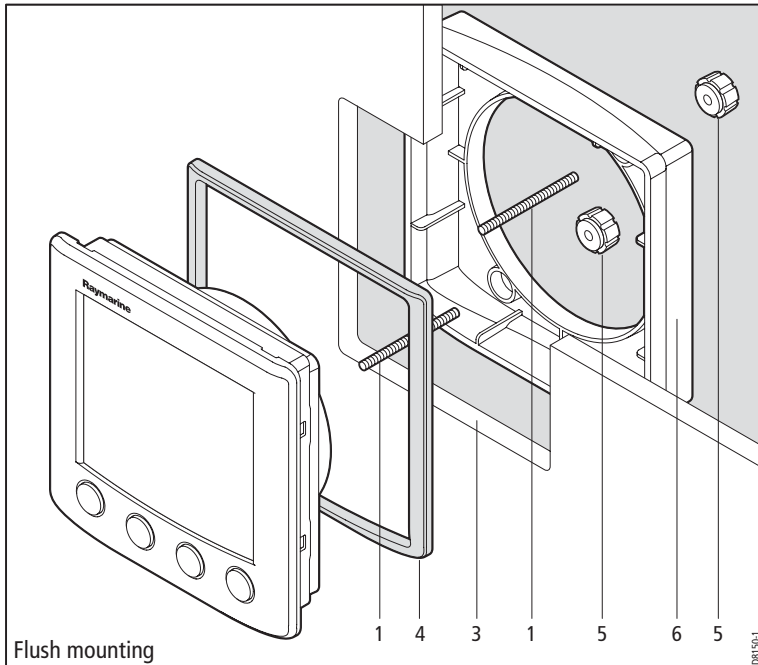

Flush mounting

8. Locate the flush mount bracket (6) onto the fixing studs and secure the assembly to the panel with the thumb-nuts (5).

Bracket mounting

A Control Unit Mounting Bracket (Part No. E25009) enables you to mount your ST60+ instrument in locations where other forms of mounting are impractical. Although this provides a useful alternative method for securing your instrument, it is only suitable for use in positions where the instrument will not be exposed to water.

To bracket mount your ST60+ instrument, do so in accordance with the Control Unit Mounting Bracket *Instruction Sheet*.

Fitting transducer

The ST60+ Tridata instrument is supplied, with appropriate through-hull Speed and Depth transducers.

Each transducer is supplied with detailed instructions for installation and maintenance. Before attempting to install a transducer, read these instructions and the *Site requirements* for transducers described in this Chapter.

Once you are satisfied you can meet all the installation requirements, install the transducer in accordance with the accompanying installation instructions.

Running transducer cable

Each transducer type has a 14 m (45 ft) cable fitted with spade terminals for connection to the ST60+ Tridata instrument. The manner in which you run the cable will depend on the locations of the transducers and instrument. The following guidelines are provided:

- If the cable has to be fed through the deck, always use a proprietary deck gland.
- Where cables are fed through holes, always use grommets to prevent chafing.
- Secure long cable runs so they do not present a hazard.
- Do not route the cable through bilges.
- Wherever possible, route the cable away from fluorescent lights, engines, radio transmitting equipment, as these may cause interference.
- The transducer cables are fitted with spade connectors for direct connection to the rear of the instrument. However, it may be necessary to remove these to facilitate installation, e.g. if a cable has to be routed through narrow apertures. Extra spade connectors are provided, to replace any that are removed when running transducer cables. When fitting spade connectors, prepare the cable as at (a) in the following illustration, then fold back the wire strands and insert into the spade connector as at (b). Ensure the wire strands do not extend beyond the rear of the spade connector insulation, then crimp the connector to the wire.

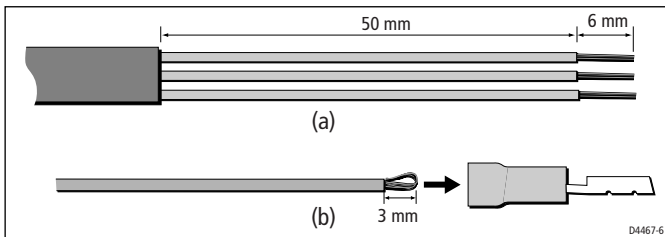

Observing the above guidelines, run the transducer cables to the ST60+ Tridata instrument.

Connecting the instrument

Types of connection

The ST60+ Tridata instrument, can be connected:

- As a stand-alone, master instrument connected directly to a Speed and/or Depth transducer.
- As a SeaTalk repeater.
- To fulfil both repeater and master roles by being connected both to the transducer and to SeaTalk.

If instruments are connected to SeaTalk, no separate power connection is necessary. Where a SeaTalk system includes an autopilot, the power for the system is provided by the autopilot.

A range of Raymarine SeaTalk extension cables is available to connect separated instruments. These cables are supplied with a SeaTalk connector fitted to each end. A junction box can be used to join cables.

Fitting ferrites

If you are going to connect a Depth transducer to an ST60+ Tridata instrument, fit suppression ferrites near the instrument end of the SeaTalk and Depth transducer cables, as follows.

1. Release the catch on the ferrite, open it up then snap it closed around the cable.
2. Position the ferrite as close as possible to the instrument end of the cable (maximum 1 foot (300 mm) from the end) and fit a tie-wrap on the cable either side of the ferrite, to hold it in position.

Note: *It is NOT necessary to fit a ferrite to the Speed transducer cable.*

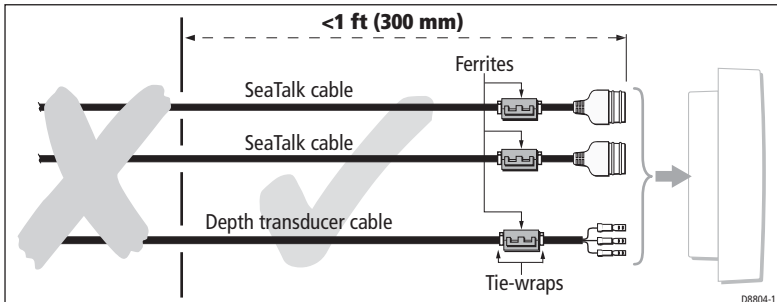

Signal connections

Make the necessary connections to your ST60+ instrument (see the *Connection to ST60+ Tridata instrument* illustration).

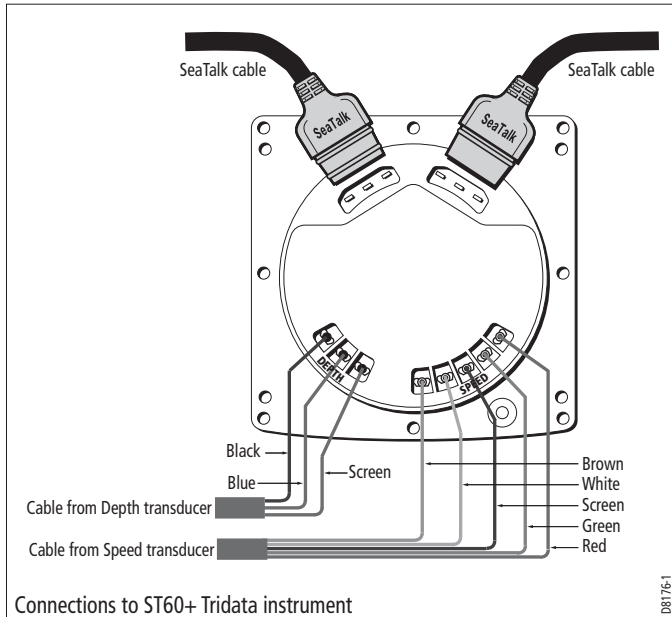

Power supply connections

CAUTION: Protect the power supply

Ensure that the 12 V power supply for the instrument is protected by a suitably rated fuse or protective circuit breaker.

SeaTalk systems

Ensure that the power supply for the SeaTalk bus is protected by a 5 A fuse or circuit breaker.

Systems with a large number of instruments on the SeaTalk bus may require connections to the power supply from each end of the system ('ring-main' style), to maintain sufficient voltage throughout the system.

This requirement depends on the total length of the cable run and the total number of instruments in the system, as follows:

Cable run	No. of instruments	Power connections
Up to 10 m	13 maximum	1
	26 maximum	2
Up to 20 m	7 maximum	1
	13 maximum	2

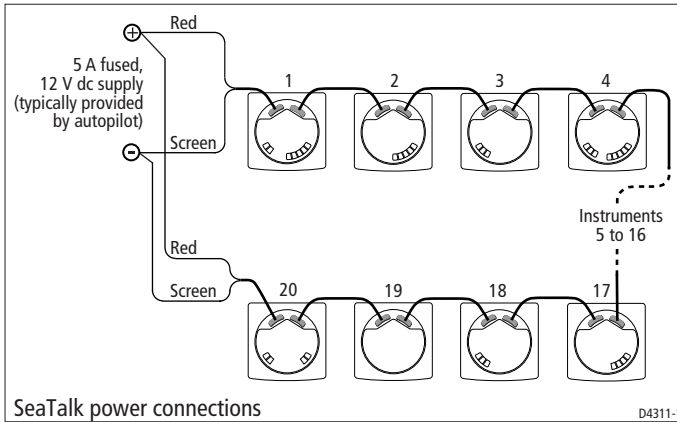

Stand alone instruments

Stand-alone instruments are not connected to SeaTalk and therefore need to be connected to an alternative 12 V power source. Power cables are available in 2 m and 9 m lengths.

To fit a power cable:

1. Ensure the intended power source is switched off. If you are using a 12 V battery, ensure the power cable is not connected to the battery.
2. Run the power cable from the instrument to a suitable 12 V dc power source.
3. If the cable has not already been trimmed at the power supply end:
 - Cut the cable to length and trim back an appropriate amount of the outer sheath.
 - Cut back and insulate the yellow wire.
4. Connect the screen to the power supply 0 V terminal.
5. Connect the red wire, via a 3 A fuse or protective circuit breaker, to the power supply +12 V terminal.

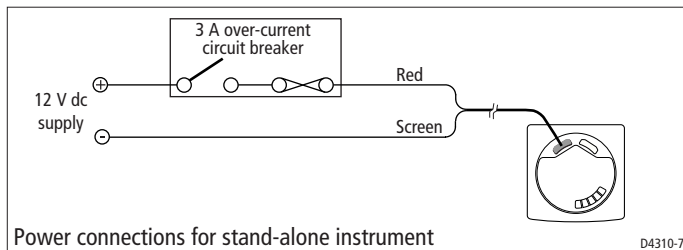

3.3 Switching on

Switch on the power to your ST60+ instrument. When the power is on, you can use the **depth** button to switch the instrument on and off as described in *Chapter 1, Operation*.

Use the procedures in *Chapter 1, Operation* to set the backlighting and contrast how you want them



WARNING: Calibration requirement

To ensure this product performs at its best on your boat, you MUST calibrate it before use, in accordance with the instructions in *Chapter 4, Calibration*. Do NOT use the product until you have successfully calibrated it.

EMC conformance

Always check the installation before going to sea to make sure that it is not affected by radio transmissions, engine starting etc.

Chapter 4: Calibration

4.1 Introduction

The ST60+ Tridata instrument is set up with factory-programmed default settings, so in order to optimise the performance of the instrument on board a particular vessel, the procedures in this Chapter must be carried out immediately after the completion of installation and before the equipment is used for navigational purposes.

Where practicable, the calibration procedures are presented diagrammatically to show the sequence of button presses and the resulting displays. Adjustment instructions are given as applicable.

4.2 User calibration

The User calibration procedures enable you to:

- Set the required units for depth readings.
- Set the offset for depth readings, i.e. determine whether depth readings are from the keel of the vessel or from the water line.
- Lock the shallow alarm.
- Set the required units for speed readings.
- Set the speed resolution.
- Select the log distance units
- Set the speed readings on the instrument to be a true indication of the actual speed of the vessel.
- Select temperature units.
- Calibrate for correct temperature readings.
- Set timer alarm buzzer on or off.

Separate routines are provided for the User calibration of the depth and speed functions. To carry out either of these routines:

1. Power up the ST60+ Tridata instrument.
2. Hold down the **depth** and **speed** buttons for approximately 2 seconds so that the User calibration entry screen is displayed.
3. Carry out the User calibration procedures for *Depth* and *Speed*.

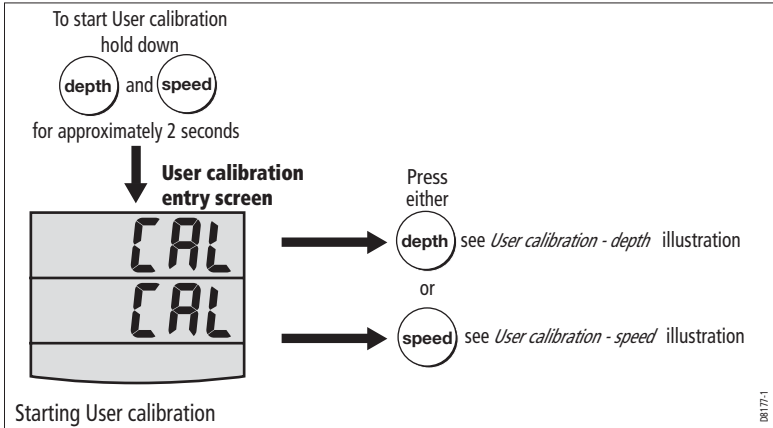

Depth

To calibrate the depth functions:

1. With the User calibration entry screen displayed, press the **depth** button.
2. Referring to the *User calibration - depth* illustration, carry out the calibration procedure. Use the **depth** button to cycle from screen to screen and the **trip** and **reset** buttons to set the required values at each screen.

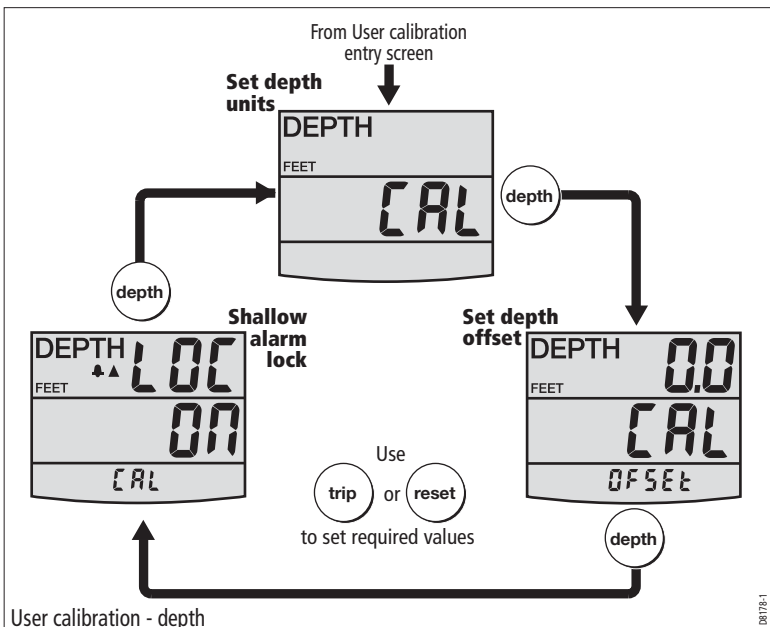

Depth units

You can set either FEET or METRES.

Depth offset

Depths are measured from the transducer to the sea bed. However, you can use the depth offset screen to apply offsets to this distance, so that the displayed depth reading represents either the depth from the keel or the depth from the water line. In order to do this, you need to know the vertical separation between the transducer position and:

- The bottom of the keel.
- The water line.

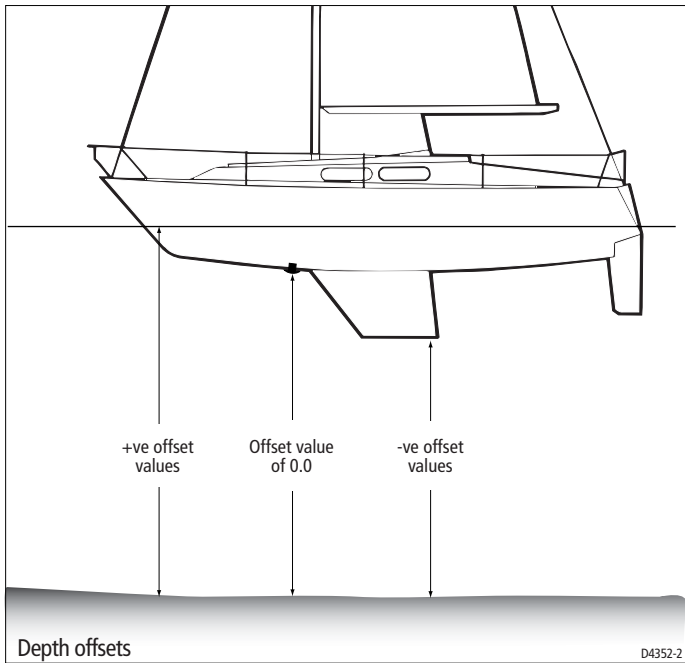

Setting offset values



WARNING: Use the correct depth offset

The use of the correct depth offset is critical to the safety of the vessel. If incorrect offset values are applied, this could result in misleading depth information being displayed with a consequent risk of running aground. Take great care to ensure you set the correct value.

Use the **trip** (decrement) and **reset** (increment) buttons to set the required offset value:

- If you want to display the depth reading from the transducer, set a value of 0.0.
- If you want to apply a water line offset, adjust the displayed reading until the appropriate positive offset value is shown.
- If you want to apply a keel offset, adjust the displayed reading until the appropriate negative offset value is shown.

Shallow alarm lock

When set to on, prevents alteration to the shallow depth alarm level.

Speed

An important reason for speed calibration is to ensure that speed readings displayed on the instrument are a true indication of the actual speed of the vessel.

In *User calibration, Speed*, you can:

- Automatically set the displayed speed reading to be the same as the Speed Over Ground (SOG) (if SOG data is available).
- Manually apply a calibration factor, to set the displayed speed to the required value.

If neither of the above methods are suitable, you can carry out a speed calibration run over a measured distance, to enable the instrument to calculate the correct calibration factor. This is described as part of *Intermediate* calibration.

To calibrate the speed functions:

1. With the User calibration entry screen displayed, press the **speed** button.
2. Referring to the *User calibration - speed* illustration, carry out the calibration procedure. Use the speed button to move from screen to screen and the trip and reset buttons to set the required values at each screen (except Adjust to SOG display).

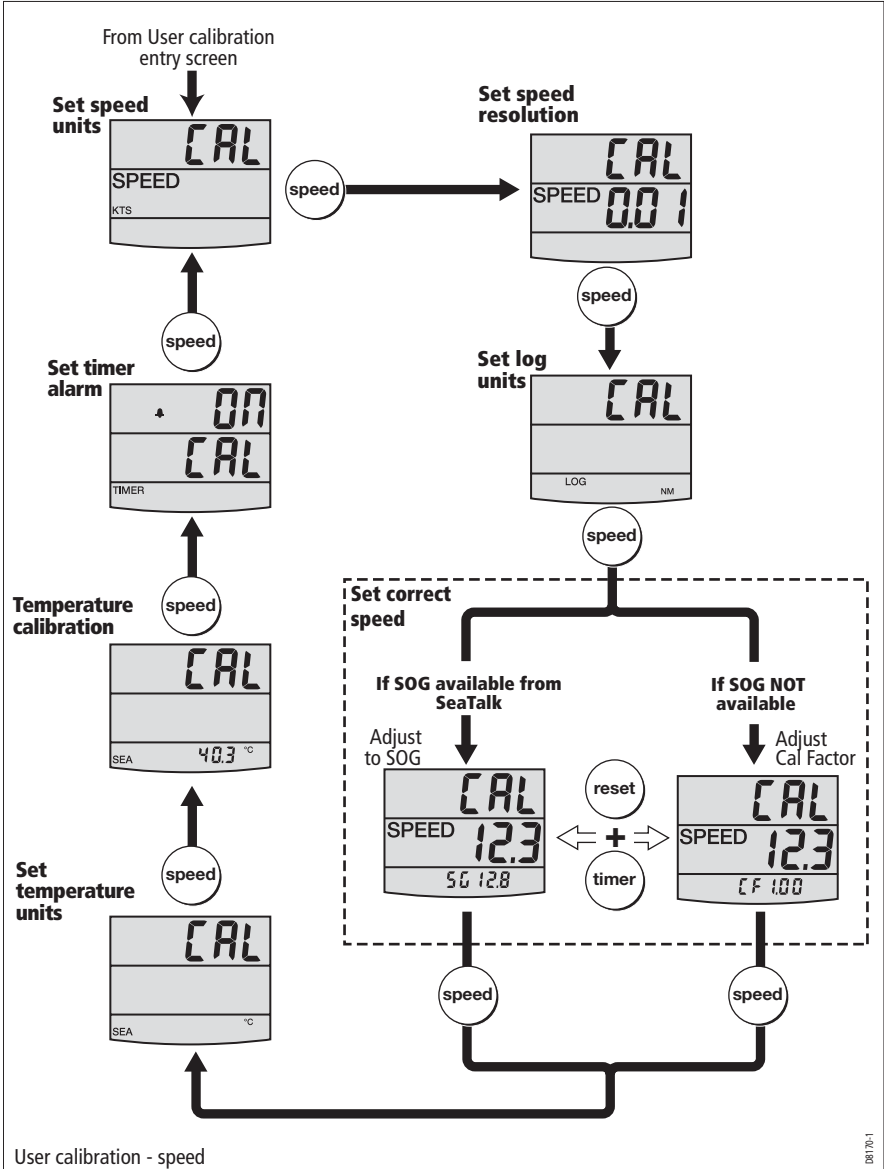

User calibration - speed

08/17/11

Set speed units

Select either KTS (knots), MPH (miles per hour) or KMH (kilometres per hour), as required.

Set speed resolution

Select resolution of either 0.01 or 0.1 as required.

Set log units

Select either NM (nautical miles), SM (statute miles) or KM (kilometres), as required.

Setting the correct speed

Set the displayed (current) speed using one of the following methods:

- If SOG is available from SeaTalk, use the Adjust to SOG screen to automatically set the current speed to. You must be running in slack tide conditions to successfully use this method.
- Manually apply a calibration factor by means of the Cal factor adjust screen, to set the displayed speed value to your best estimate of the vessel's speed.

If neither of the above methods is suitable, use the *Speed calibration* procedure described under *Intermediate calibration* to carry out a speed calibration run over a measured distance. This enables the instrument to calculate the correct calibration factor.

Adjust to SOG

The Adjust to SOG screen is displayed only if SOG data is available from SeaTalk. The current SOG is displayed in the bottom section of the display (SG 12.8 in the illustration), and the current speed registered by the instrument, as large figures in the middle section of the display (12.3 in the illustration).

It is recommended that, if you are running in slack tide conditions, you press the **reset** button for 3 seconds, to accept the SOG as the current speed.

If you do not wish to accept SOG as the current speed, press the **trip** and **reset** buttons together to select the Cal factor adjust display.

Cal factor adjust

The Cal factor adjust screen enables you to manually adjust the calibration factor. It shows the current calibration factor in the bottom section of the display (CF 1.00 in the illustration), and the current speed as large figures (12.3 in the illustration).

Use the **trip** or **reset** button to adjust the calibration factor so that the current speed is the speed through the water.

If SOG data is available from SeaTalk, you can turn to the Adjust to SOG screen by pressing the **trip** and **reset** buttons.

Note: *If neither of the above methods gives satisfactory results, carry out the Speed calibration procedure (part of Intermediate calibration).*

Set temperature units

Select either °C or °F, as required.

Temperature calibration

Set the display to show the current water temperature.

Timer alarm buzzer

Switches the count-up and race-start timer audible alarm on the ST60+ Tridata instrument being calibrated, on and off.

Leaving User calibration

Hold down the **depth** and **speed** buttons for 2 seconds, to save your settings, exit User calibration and resume normal operation.

4.3 Intermediate calibration

Intermediate calibration enables you to:

- Check the instrument software version.
- Check the instrument status - either YES (master) or NO (repeater). You can also change the depth status, as required. This feature is particularly useful in preventing interference when using another product (e.g. a fishfinder) that operates at 200 kHz.
- Carry out a calibration run over a measured distance to ensure accurate speed readings.

To start Intermediate calibration, hold down the **depth** and **speed** buttons for approximately 4 seconds (see *Intermediate calibration* flow chart).

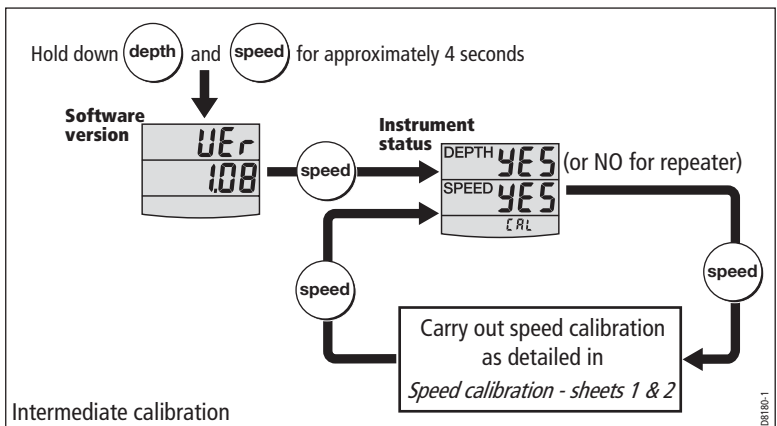

To set the instrument status:

1. Press the **depth** button to select the Instrument status screen.
2. Press the **trip** and **reset** buttons simultaneously to enter the depth adjust mode, then press either **trip** or **reset** to set the required status, i.e. either YES (for master operation) or NO (for repeater operation).

Note: *You must not allocate more than one master depth instrument in any system.*

3. Press the trip and reset buttons simultaneously again, to leave the adjust mode.

Note: *If a fishfinder is connected to the same SeaTalk system as your ST60+ Tridata instrument and is switched on, all ST60+ Depth and Tridata instruments in the system will display FISHFINDER depth information from SeaTalk. Under these conditions, a master ST60+ Tridata instrument will act as a slave, and in Intermediate calibration, the YES legend will change to SLA when not in adjust mode.*

Speed calibration

The speed calibration procedure involves carrying out two runs over a measured distance, to enable a calibration factor to be determined and applied to your ST60+ Tridata instrument, to ensure optimum accuracy. Each calibration run comprises outward and return legs, to minimise the affect of tidal drift when the calibration factor is determined.

Note: *It is recommended that the speed calibration procedure is carried out in conditions of minimum tidal drift.*

To carry out a speed calibration, start the Intermediate calibration procedure and use the **speed** button to proceed to the Calibration run length screen (see *sheet 1* of the *Speed calibration* flow chart). Proceed with the speed calibration as follows:

1. With the Calibration Run Length screen displayed, simultaneously press the **trip** and **reset** buttons, to enter adjust mode. In this mode, the displayed run length flashes on and off.
2. Set the length of the intended calibration run, using either the **trip** button to decrement or the **reset** button to increment the run length value. You can set any value between 0.25 and 2.50.
3. Press trip and reset buttons together to commence the speed calibration. The Cal status screen is displayed. The information at the bottom of the screen alternates between Strt 1 and the calibration factor (CF) currently applied.
4. Start the outward leg of the calibration run and as you pass the start point, press the **speed** button, so that the text out shows at the bottom of the screen. As the calibration run proceeds, the displayed value will increment.

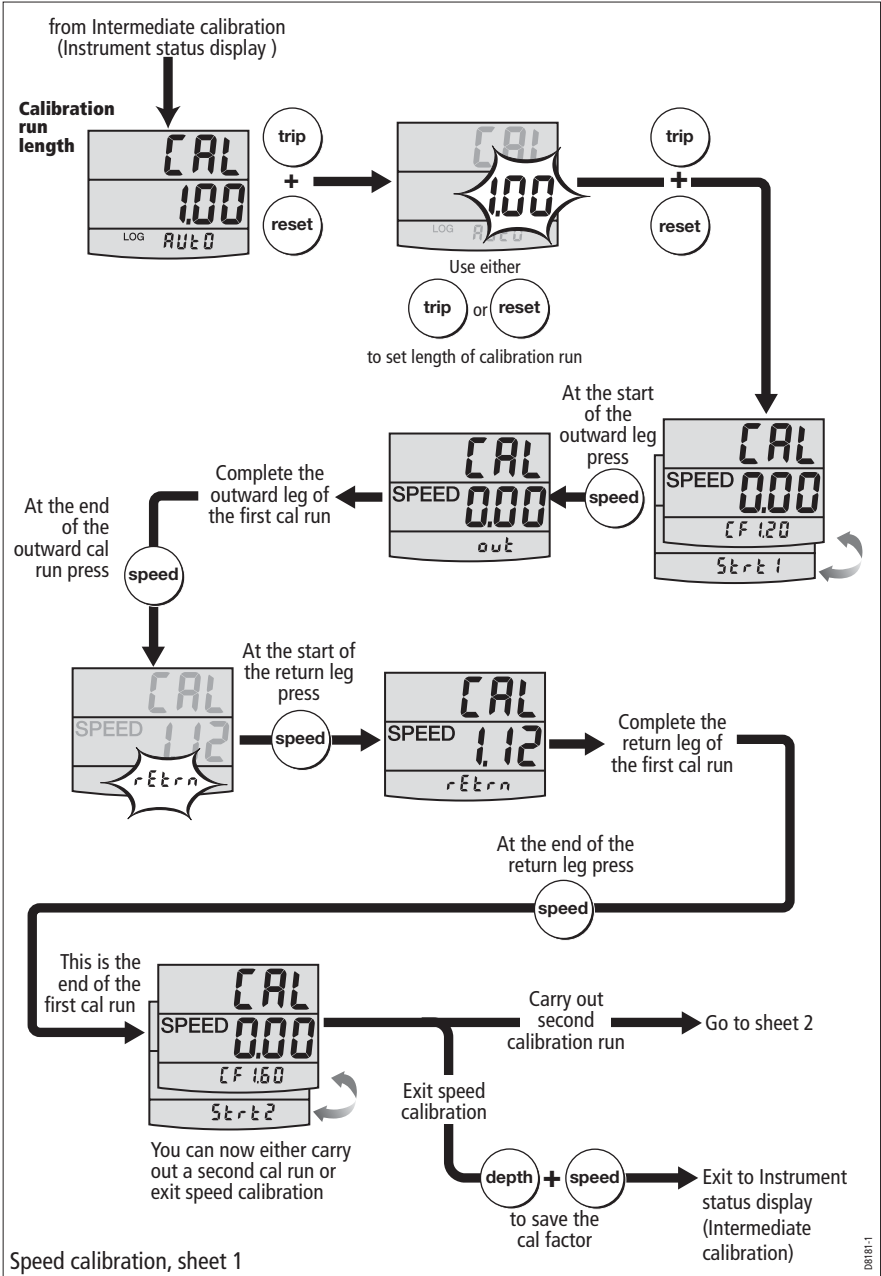

Speed calibration, sheet 1

D8181-1

5. At the end of the outward leg, press the **speed** button again so that:
 - The text **rEtrn** is flashing at the bottom of the screen.
 - The displayed distance freezes. Note that this value may not be the same as the measured distance due to errors introduced by tidal flow.
6. Turn the vessel round, start the return leg and as you do so, press the **speed** button so the **rEtrn** legend stops flashing and the displayed value increments.
7. At the end of the return leg, press the **speed** button to end the calibration run. At this point:
 - The text **Strt 2** alternating with the new calibration factor is displayed at the bottom of the screen.
 - The displayed distance freezes. This value should be very close to the actual (measured) distance of the calibration run.

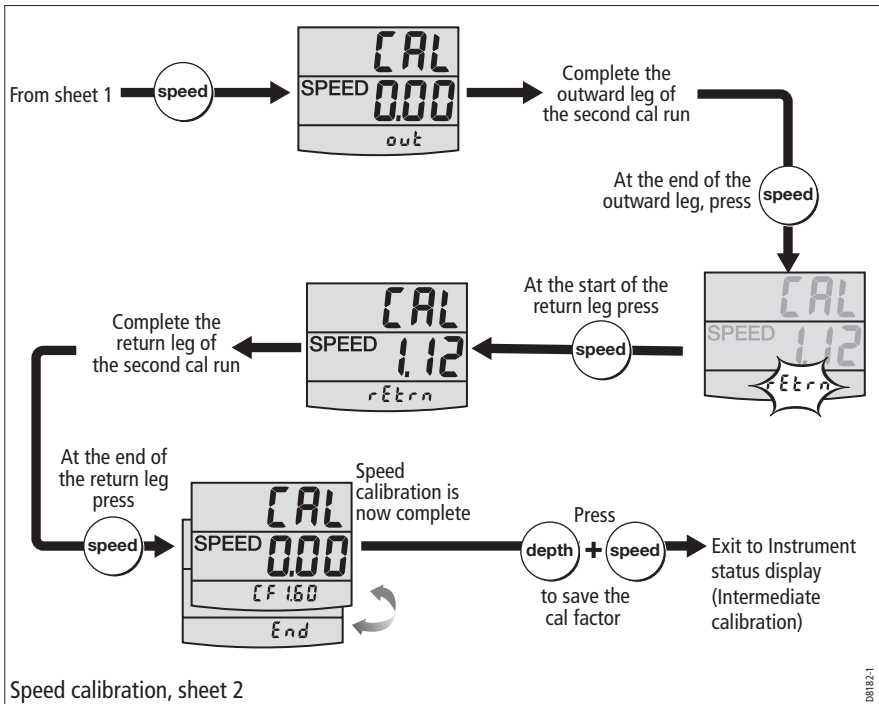

8. Carry out one of the following actions:
 - If you are satisfied with the results of the first calibration run, press the **depth** and **speed** buttons together, to store the new calibration factor, exit speed calibration and return to the Instrument status screen.

- If you want to carry out a second calibration run:
 - i. Press **speed** to start the second calibration run (see *sheet 2* of the *Speed calibration* flow chart).
 - ii. Use the procedure described above in steps 4 to 7, to complete the second run. At the end of the second run, the text **END** alternating with the new calibration factor is displayed at the top of the screen.
 - iii. Press the **depth** and **speed** buttons together, to store the new calibration factor, exit speed calibration and return to the Instrument status screen.

Leaving Intermediate calibration

Hold down the **depth** and **speed** buttons for 2 seconds, to save your settings, exit Intermediate calibration and resume normal operation.

4.4 Dealer calibration

The Dealer calibration procedures enable the following parameters to be set:

- User calibration on/off.
- Data source for speed information.
- Speed response.
- Depth response.
- Boat show mode on/off.

Dealer calibration also gives access to the Factory defaults screen. This enables you to re-apply the factory settings if you want to reset the instrument to a known operating condition.

To commence Dealer calibration, hold down the **depth** and **speed** buttons together for approximately 12 seconds, to select the Dealer calibration entry page (see *Dealer calibration* diagram). Then press the **trip** and **reset** buttons together, to enter the calibration screen sequence.

Use the **depth** button to move from screen to screen and the **trip** or the **reset** button to set the required values at each screen.

User calibration on/off

Press either the **trip** or **reset** button to toggle the User calibration on or off as required. With off selected, User calibration and Intermediate calibration are both disabled.

Speed select (SOG on/off)

Use this screen to select the data source for displayed speed information. Press either the **trip** or **reset** button to toggle SOG ON or OFF as required. With SOG OFF selected, speed information is obtained from the speed transducer. This is the recommended setting if you have a speed transducer fitted.

With SOG ON selected, speed information is obtained from the SOG input.

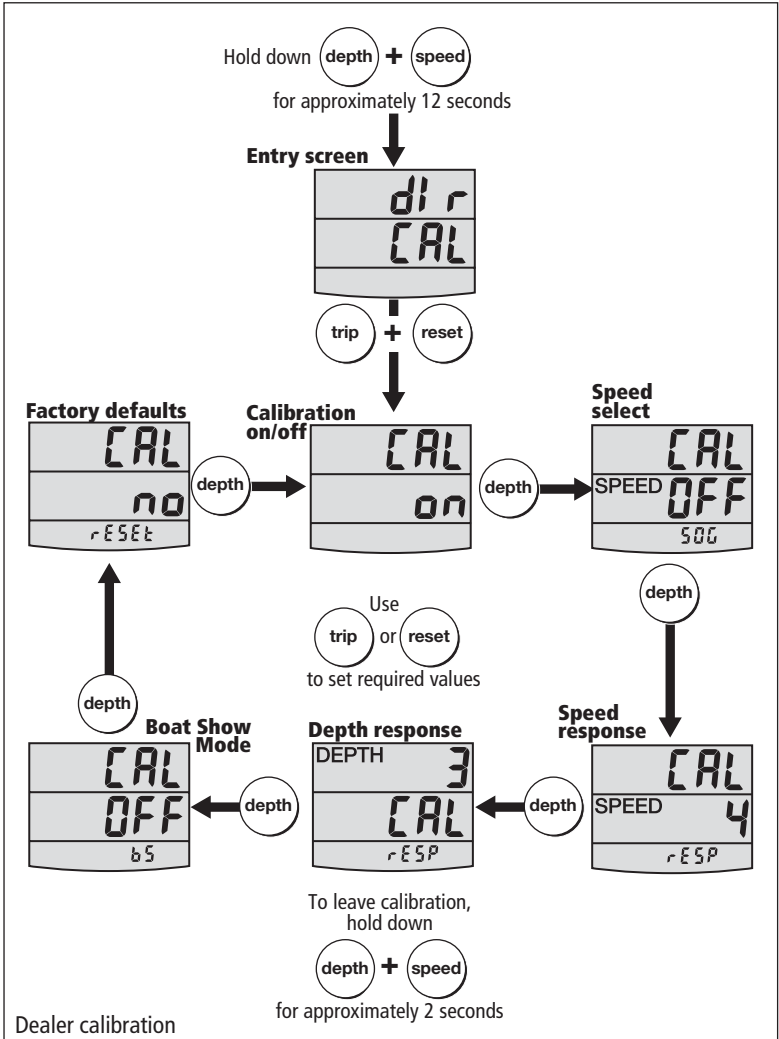

Response settings

The response values for both SPEED and DEPTH determine the frequency at which information is updated. A low number provides a smooth response and a high number a much livelier update.

Use the **trip** (decrement) and **reset** (increment) buttons to set the required value. Response values are from 1 to 15.

Boat show mode

CAUTION: Do NOT enable Boat Show Mode

Do NOT enable Boat Show Mode. This must be used only for demonstration purposes.

Ensure that the Boatshow Mode Use is set to OFF. If necessary, use the **trip** or **reset** button to achieve this.

Factory defaults

You can use this screen to reset the operating parameters to the factory default values. Use the **trip** and **reset** buttons to make the required selection.

Note that the selection you make at this screen will be applied when you exit the screen, so be sure you make the correct selection.

To retain the current values, ensure that the display shows NO.

If you want to apply the factory defaults, change the display to YES. If you do this, the values you have set up will be overwritten by the factory defaults when you leave this screen.

Leaving Dealer calibration

Hold down the **depth** and **speed** buttons for 2 seconds to save your settings, exit Dealer calibration and resume normal operation.

Glossary

APP	Apparent
AVE	Average
AWA	Apparent Wind Angle (relative to the vessel)
AWS	Apparent Wind Speed
BTW	Bearing To Waypoint
CMG	Course Made Good
COG	Course Over Ground
DMG	Distance Made Good
DTW	Distance To Waypoint
EMC	Electro Magnetic Compatibility
ETA	Estimated Time of Arrival
GPS	Global Positioning System
HDG	Heading
KM	Kilometer(s)
KMH	Kilometers per hour
KTS	Knot(s)
LAT	Latitude
LCD	Liquid Crystal Display
LON	Longitude
LTR	Liter(s)

M	Magnetic or meters
MAG	Magnetic
MOB	Man Overboard
MPH	Miles per hour
NM	Nautical mile(s)
Response	The sensitivity of an instrument, to data changes.
RF	Radio Frequency
SeaTalk	Raymarine proprietary communication system which links products, to provide a single, integrated system sharing power and data.
SM	Statute mile(s)
SOG	Speed Over Ground
SPD	Speed
T	True
TTG	Time To Go
TWA	True Wind Angle relative to the vessel, taking into account the speed of the vessel.
TWD	True Wind Direction.
TWS	True Wind Speed.
VMG	Velocity Made Good.
WP	Waypoint
XTE	Cross Track Error

Index

A

Average speed, 5

B

Backlighting adjustment, 8

Boat log, 7

Boat show mode, 41

Boat speed, 4

Buzzer, 7

C

Calibration requirement, 1, 27

Cleaning, 9

Condensation, 9

Contrast adjustment, 8

Current depth, 2

D

Dealer calibration, 39

Depth alarms, 3
adjusting levels, 4

Depth information, 2
current depth, 2

Depth offset, 32

Display setup, 8

Disposing of the product, ii

E

EMC information, i, 9, 16, 27

F

Factory defaults, 41

H

Help lines, 11

I

Installing

- instrument, 18
 - bracket mounting, 22
 - flush mounting, 19
 - requirements, 15
 - signal connections, 25
 - surface mounting, 18

- planning, 13
- transducer, 22
 - running cable, 23
 - transducers
 - requirements, 13

Installing instrument

- power supply connections, 25

Instrument mounting options, viii, 18

Intermediate calibration, 35

L

Log screen, 7

M

Maximum speed, 5

Mounting options (instrument), viii, 18

P

Power supply

- SeaTalk systems, 25
- stand alone instrument, 26

Product disposal, ii

R

Race start timers, 7

buzzer, 7

settings, 7

Remote control, viii, 8

Reset

- average speed reading, 5
- maximum speed reading, 5
- trip distance reading, 8

S

Safety

- calibration requirement, 1, 27
- electrical, i
- ensuring correct depth offset, 32
- general, i
- navigation, i

SeaTalk overview, vii

Servicing & safety, 9

Setting up

- applying factory defaults, 41
 - backlighting, 8
 - contrast, 8
 - correct speed, 34, 36
 - depth offset, 31
 - depth units, 31
 - distance units, 34
 - instrument response, 41
 - race start timer, 7
 - resolution, 34
 - selecting speed data source, 40
 - speed units, 33
 - temperature reading, 35
 - temperature units, 35
 - User calibration access, 39
- Shallow alarm lock, 32
- Site requirements
- instrument, 15
 - transducers, 13
- Software version, 35
- Software version number, 12
- Speed calibration
- methods, 34
 - procedure, 36
 - purpose, 32
- Speed information
- average speed, 5
 - boat speed, 4
 - maximum speed, 5
 - VMG, 5
- Switching on/off, 1, 27

T

- Technical support, 11
- Temperature (water), 6
- Timer buzzer
 - switch on/off, 35
- Timers, 6
 - buzzer, 7
 - race start timers, 7
 - setting, 7
- Trip distance, 8
- Troubleshooting, 10

U

- User calibration, 29

V

- Velocity Made Good, 5

W

- Water temperature, 6

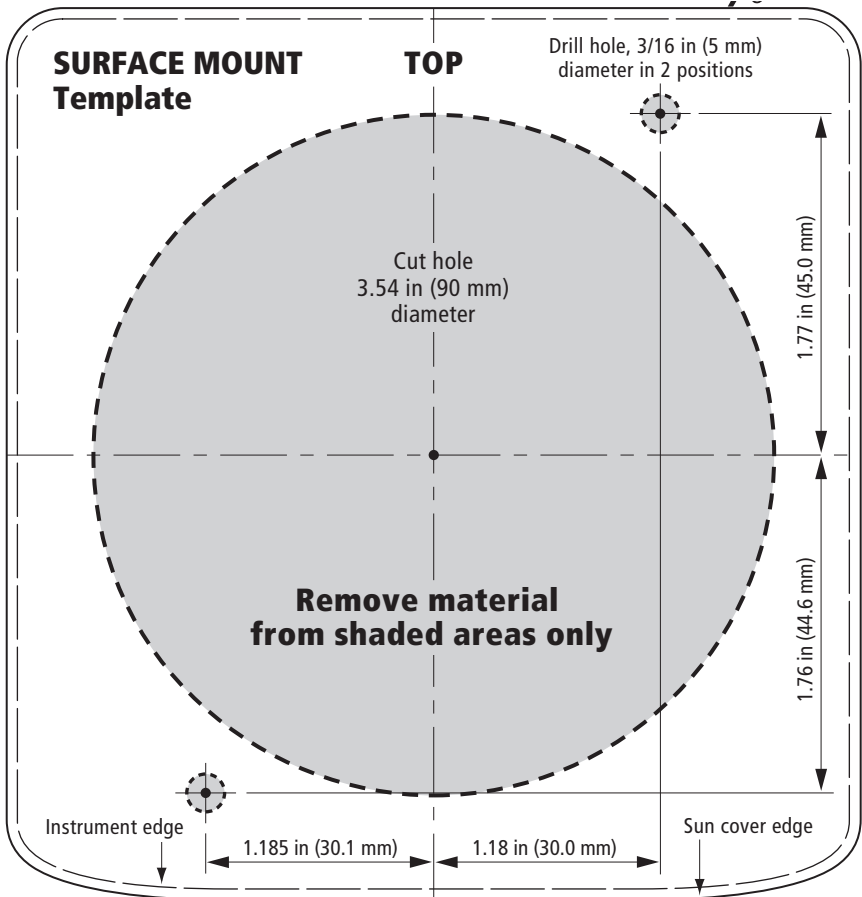

DB157-1

SURFACE MOUNT template for ST60+ Instruments

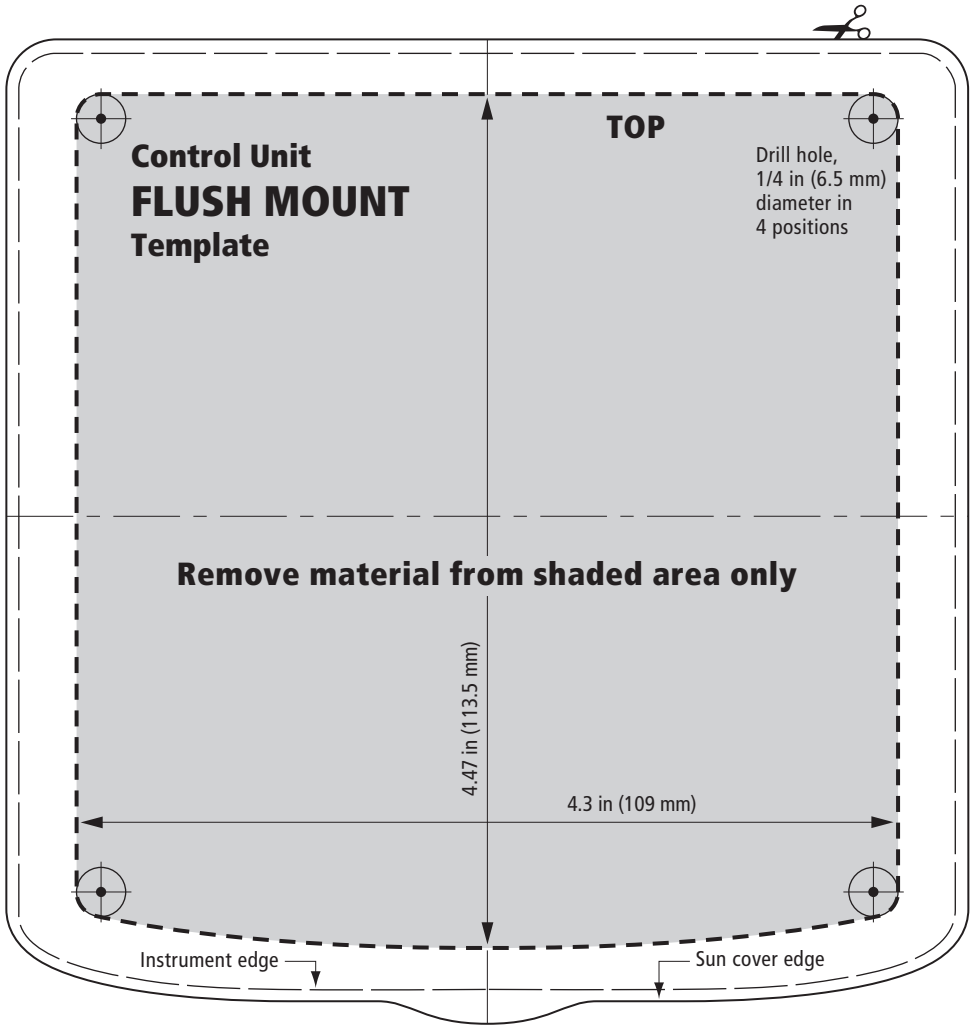

**FLUSH MOUNT template for
ST60+ Instruments**

